

SPECIFICATIONS:

1. ELECTRICAL CHARACTERISTICS:
 - 1-1. CURRENT RATING: 1.5A MAX.
 - 1-2. VOLTAGE RATING: 150V MAX.
 - 1-3. CONTACT RESISTANCE: 50mΩ MAX.(INITIAL), 100mΩ MAX.(AFTER LIFE TEST).
 - 1-4. INSULATION RESISTANCE: 100MΩ MIN.
 - 1-5. Dielectric Withstanding Voltage : 500 V AC
2. MECHANICAL CHARACTERISTICS:
 - 2-1. DURABILITY: 5000 CYCLES.
 - 2-2. INSERTION FORCE: 2.25kg MAX. WITH LATCH DEPRESSED.
 - 2-3. WITHDRAWAL FORCE: 4.5kg MAX. WITH LATCH DEPRESSED.
 - 2-4. OPERATING TEMPERATURE:-30℃ ~ +70℃.
3. MARKING: MARK "S" INSIDE OF THE CONNECTOR.
4. PACKAGING : TAPE & REEL.
5. TO CONFORM TO SINGATRON HAZARDOUS SUBSTANCE FREE SPEC.
6. HALOGEN FREE PRODUCT IDENTIFICATION
7. HALOGEN FREE PRODUCT IDENTIFICATION LOGO ON THE PACKAGING: 
8. FOR REFLOW SOLDERING LEAD-FREE PROCESS.
9. PRINTED DATE CODE "YY MM DD" ON TOP OF THE CONNECTOR.



NODE	COLOR	Wavelength
A1(+)	A2(-)	GREEN
B1(+)	B2(-)	AMBER

NO	DESCRIPTION	QTY	MATERIAL	PLATING & COLOR
F	STOP	2	HIGH TEMP.THERMOPLASTIC	UL 94V-0 & Yellow
E	LED 2	1		AMBER
D	LED 1	1		GREEN
C	SHELL	1	STAINLESS STEEL	NICKEL
B	TERMINAL	8	PHOSPHOR BRONZE	NI PLATING ALL OVER C/F ON CONTACT AREA. Matte Sn 80μ" ON SOLDER TAIL. ALL OVER Ni 50μ"MIN.
A	HOUSING	1	HIGH TEMP.THERMOPLASTIC	UL 94V-0 & BLACK

 Singatron Enterprise Co., Ltd.
信登企業股份有限公司

TITLE	REV.	DATE
RJ45 JACK <td>1</td> <td>2018.08.09</td>	1	2018.08.09
PAN	2	2019.06.14

REV.	ECN NO OR DESCRIPTION	REVISED	DATE
A	PDR NO: T171109-1A	ALLEN	2018.08.09
B	ECN NO: S190615-R	PAN	2019.06.14

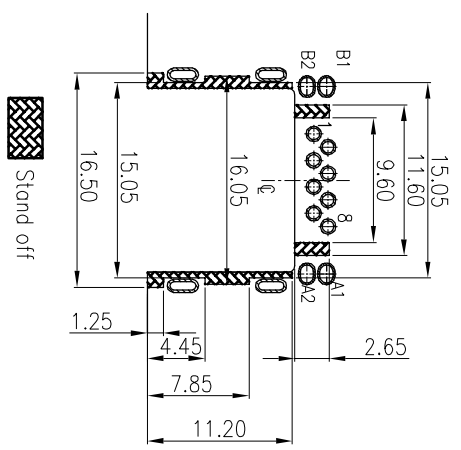
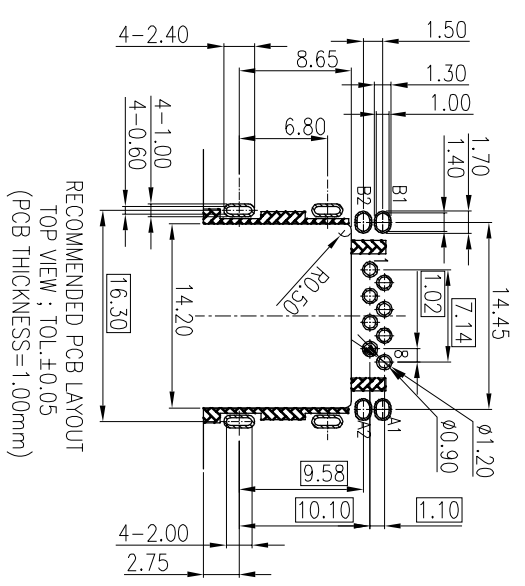

RJ45插入最小有效接觸行程

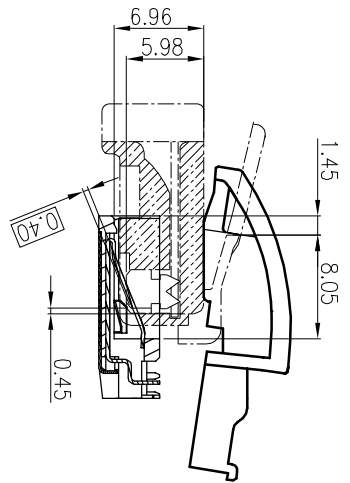

RJ45插入最大有效接觸行程

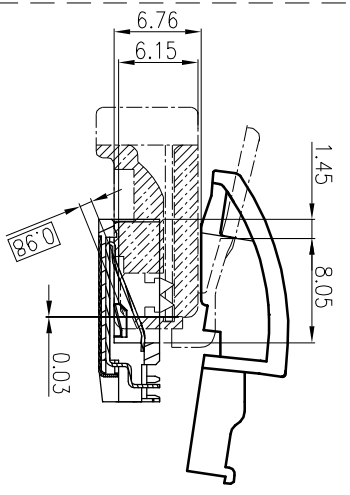

防R11插入模似分析

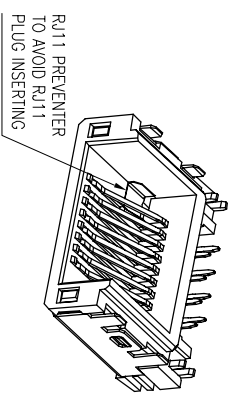
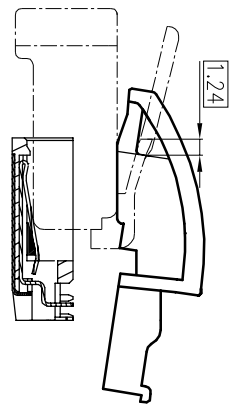

NO	DESCRIPTION	QTY	MATERIAL	PLATING & COLOR
UNLESS OTHERWISE SPECIFIED TOLERANCES				
Stand off				

Singatron Enterprise Co., Ltd.
信音企業股份有限公司

DECIMALS:		ANGLES:		TITLE
X	:±0.5	X	:±2°	DWN PAN
X.X	:±0.3	X.X	:±1°	CHKD JAMES
X.XX	:±0.2			APVD BOYE

RJ45 JACK
 PART NO. 2RJ3081-1B8211F
 SCALE 4:1 UNIT: mm
 SHEET 2 OF 2 REV: B
 CUSTOMER COPY