

REV.	ECN NO OR DESCRIPTION	REVISED	DATE
R	ECN NO: S120324	Angus	2012.05.31
S	ECN NO: S150320-Q	YUREN	2015.05.22
T	ECN NO: S150941-E	YUREN	2015.12.11

SPECIFICATIONS:

- INSERTION FORCE: 3.0KG MAX.
WITHDRAWAL FORCE: 1.0KG-3.0KG.
- INSULATION RESISTANCE BETWEEN ANY ADJACENT TERMINALS SHALL NOT BE LESS THAN 100 MEGOHMS BY 500 VOLTS MEGGER.
- JACK SHALL WITHSTAND 250 VOLTS BETWEEN ANY ADJACENT TERMINAL FOR ONE MINUTE.
- CONTACT RESISTANCE SHALL NOT EXCEED 30mΩ
- JACK SHALL WITHSTAND 5,000 CYCLES OF INSERTION AND WITHDRAWAL WITH TESTING PLUG, AND CONTACT RESISTANCE SHALL NOT EXCEED 50mΩ
- MEASURING CONDITION:
TEMPERATURE: FROM 5°C TO 35°C.
RELATIVE HUMIDITY: FROM 40% TO 85%.
- ENVIRONMENTAL SPECIFICATIONS:
7.1 HUMIDITY TEST: HUMIDITY 90% TO 95% TEMPERATURE 40°C ± 2°C FOR 96 HOURS.
7.2 HEAT TEST: TEMPERATURE 70°C ± 2°C (HUMIDITY BELOW 50%) FOR 96 HOURS.
7.3 COLD TEST: TEMPERATURE -40°C ± 2°C FOR 96 HOURS.
- PACKAGING: TAPE & REEL
- PRINTED DATE CODE "YYMMDD" ON TOP OF CONNECTOR.

- RATING: DC 20V 7A 43uF and DC 20V 10A 43uF DEPEND ON MATING PLUG DETAIL TYPE
- SOLDER HEAT RESISTANCE: 260°C 10 SECS.
- TO CONFORM TO SINGATRON HAZARDOUS SUBSTANCE FREE SPEC.
- GREEN PRODUCT IDENTIFICATION MARK ON JACK:
- GREEN PRODUCT IDENTIFICATION LABEL ON PACKAGING:
- FOR WAVE SOLDERING LEAD-FREE PROCESS.

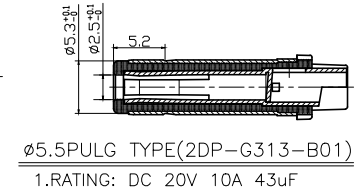
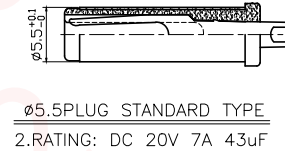
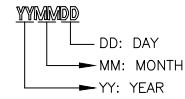

F	GROUND	1	STAINLESS STEEL 0.15t	N/A
E	SHELL	1	SPCC 0.4t	Solderable Ni
D	STOPPER	1	HIGH TEMP.THERMOPLASTIC UL94V-0	NATURE
C	PIN	1	BRASS	Ag 20u" Min.
B	SPRING	1	COPPER ALLOY 0.3t	Sn 60u"Min, Ni 60u"Min.
A	BODY	1	HIGH TEMP.THERMOPLASTIC UL94V-0	BLACK
NO	DESCRIPTION	QTY	MATERIAL	PLATING & COLOR

UNLESS OTHERWISE SPECIFIED TOLERANCES

DECIMALS: ANGLES:
X :±0.5 X :±2°
X.X :±0.3 X.X :±1°
X.XX :±0.2

Singatron Enterprise Co., Ltd. 信音企業股份有限公司	
DC POWER JACK	
DWN	YUREN PART NO.2DC-G213B200
CHKD	CERRY SCALE:4:1 UNIT: mm
APVD	LIAO SIZE: A3 SHEET:1 OF 1 REV:T
CUSTOMER COPY	

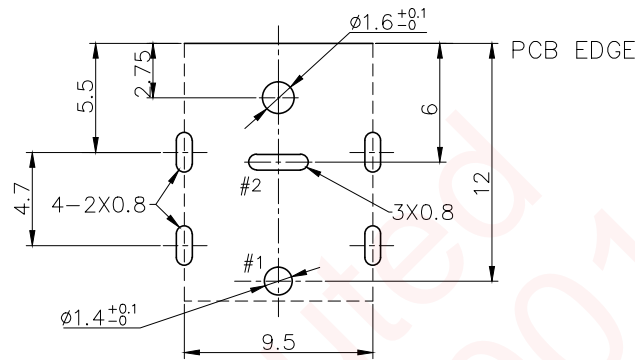
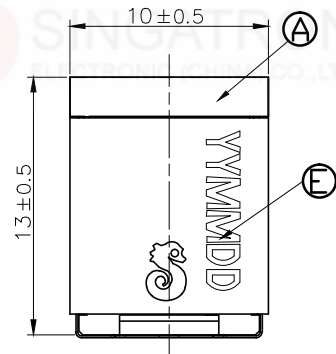

RECOMMEND P.C.B LAYOUT
TOP VIEW (TOLERANCE ±0.05)

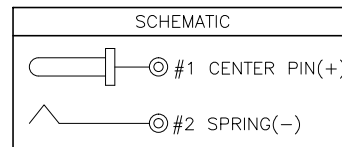
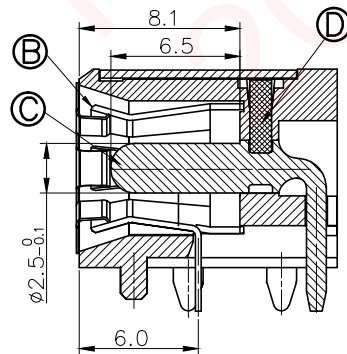
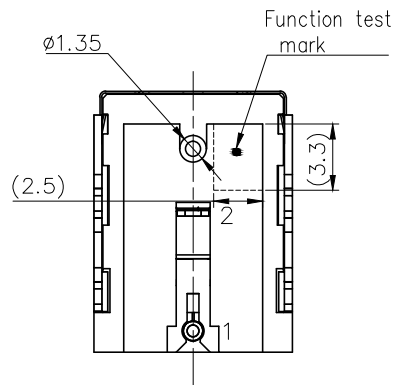
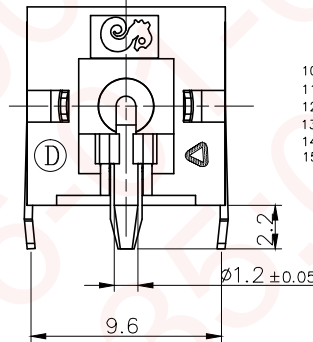
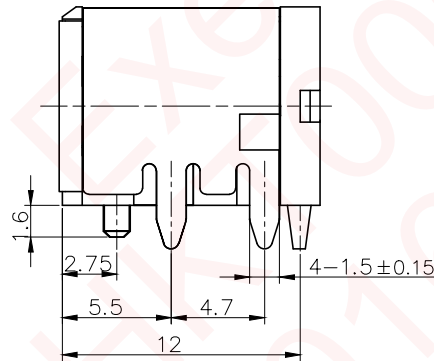
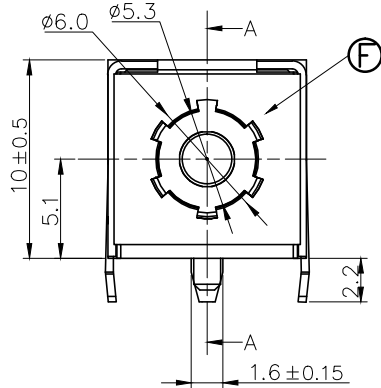

Section A-A