

- SPECIFICATIONS:**
- ELECTRICAL CHARACTERISTICS:**
    - 1-1. RATING: 60V DC 60A
    - 1-2. CONTACT RESISTANCE: 0.35mΩ MAX.(INITIAL)
  - MECHANICAL CHARACTERISTICS:**
    - 2-1. INSERTION FORCE : 10 KGF Max.(INITIAL)
    - 2-2. WITHDRAWAL FORCE :10.0 KGF Max.(INITIAL)
  - LIFE TEST: 5,000 CYCLES MIN.
  - OTHER GENERAL SPEC: TO REFER "2BA1010-000210 SPEC".
  - TO CONFORM TO SINGATRON HAZARDOUS SUBSTANCE FREE SPEC.
  - GREEN PRODUCT IDENTIFICATION MARK ON JACK:
  - PRODUCT IDENTIFICATION LABEL ON PACKAGING:
  - PACKAGING: BAG

**SCHEMATIC**

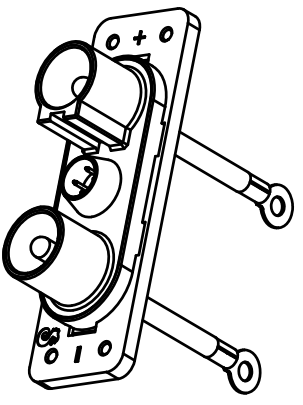
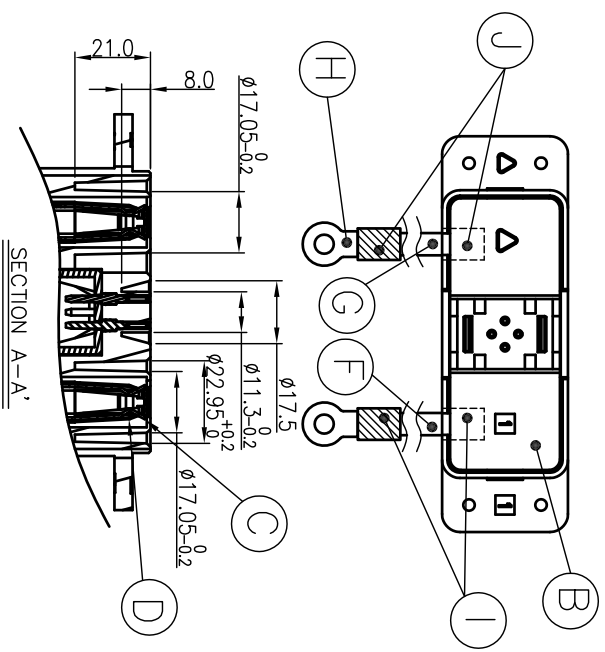
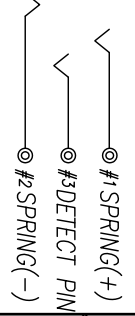

MATING PART  
P/N : 2BA1011-000210

REV.	ECN NO.	OR DESCRIPTION	REVISED	DATE
A		PRODUCT RELEASE	JASON	2010.05.25

NO	DESCRIPTION	QTY	MATERIAL	PLATING & COLOR
J	HEAT SHRINK TUBE	2	L=20.0	RED COLOR
I	HEAT SHRINK TUBE	2		BLACK COLOR
H	R-TERMINAL	2	OD 12 ID 5.3 (R8-5)	TIN PLATING
G	WIRE	1	UL1028 #8	RED COLOR
F	WIRE	1	UL1028 #8	BLACK COLOR
E	DETECT PIN	4	COPPER ALLOY	GOLD PLATING
D	SPRING	2	SUS304 0.5t	N/A
C	TERMINAL	2	COPPER ALLOY 0.8t	SILVER PLATING
B	COVER	1	HIGH TEMP. THERMOPLASTIC UL 94V-0	BLACK COLOR
A	HOUSING	1	HIGH TEMP. THERMOPLASTIC UL 94V-0	BLACK COLOR

Singatron Enterprise Co., Ltd.  
信音企業股份有限公司

BATTERY CONNECTOR+WIRE

PART NO. 2BA1010-000210

TITLE	DECIMALS:	ANGLES:
DWN	:±0.5	X : ±2°
CHKD	:±0.3	X.X : ±1°
APVD	:±0.2	X.XX : ±0.2

CUSTOMER COPY