

- SPECIFICATIONS:
- ELECTRICAL CHARACTERISTICS:
 - RATING: 60V DC 60A
 - CONTACT RESISTANCE: 0.35mΩ MAX.(INITIAL)
 - MECHANICAL CHARACTERISTICS:
 - INSERTION FORCE : 10 KGf Max.(INITIAL)
 - WITHDRAWAL FORCE : 10.0 KGf Max.(INITIAL)
 - LIFE TEST: 5,000 CYCLES MIN.
 - OTHER GENERAL SPEC. TO REFER "2BA1011-000210 SPEC."
 - TO CONFORM TO SINGATRON HAZARDOUS SUBSTANCE FREE SPEC.
 - GREEN PRODUCT IDENTIFICATION MARK ON JACK:
 - PRODUCT IDENTIFICATION LABEL ON PACKAGING:
 - PACKAGING: BAG

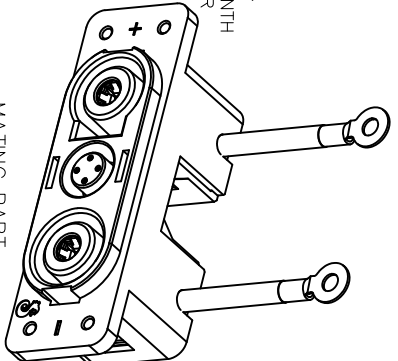

MATING PART
P/N : 2BA1010-000210

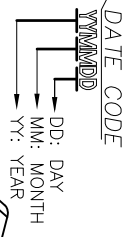
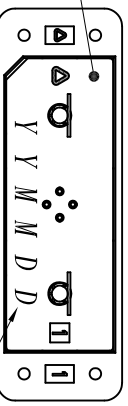
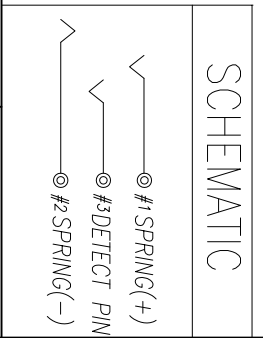
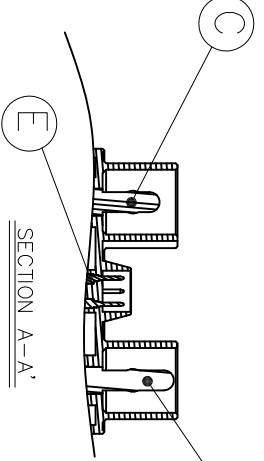

J	HEAT SHRINK TUBE	2	L=20	BLACK COLOR
I	HEAT SHRINK TUBE	2	L=20	RED COLOR
H	R-TERMINAL	2	OD 12 ID 5.3 (R8-5)	TIN PLATING
G	WIRE	1	UL1028 #8	RED COLOR
F	WIRE	1	UL1028 #8	BLACK COLOR
E	DETECT PIN	4	COPPER ALLOY	GOLD PLATING
D	PIN(-)	1	COPPER ALLOY	SILVER PLATING
C	PIN(+)	1	COPPER ALLOY	SILVER PLATING
B	COVER	1	HIGH TEMP. THERMOPLASTIC UL 94V-0	BLACK COLOR
A	HOUSING	1	HIGH TEMP. THERMOPLASTIC UL 94V-0	BLACK COLOR
NO	DESCRIPTION	QTY	MATERIAL	PLATING & COLOR
UNLESS OTHERWISE SPECIFIED TOLERANCES				
Singatron Enterprise Co., Ltd. 信亨企業股份有限公司				
TITLE BATTERY CONNECTOR+WIRE				
DWN	2010.06 JASON	PART NO.2BA1011-000210		
CHKD	2010.08 ANGELA	SCALE:0.5:1	UNIT: mm	
APVD	JACK-M10	SIZE: A3	SHEET: 1 OF 1	REV: A

DECIMALS: ANGLES:

X :±0.5 X :±2°

X.X :±0.3 X.X :±1°

X.XX :±0.2

CUSTOMER COPY

REV.	ECN NO.	OR DESCRIPTION	REVISED	DATE
A		PRODUCT RELEASE	JASON	2010.05.25