

REV. ECN NO OR DESCRIPTION	REVISED	DATE
A PRODUCT RELEASE	JASON	2011.10.25

SPECIFICATIONS:

- ELECTRICAL CHARACTERISTICS:
 - RATING: 60V DC 60A
 - C-CONTACT RESISTANCE: 0.35mΩ MAX.(INITIAL)
- MECHANICAL CHARACTERISTICS:
 - INSERTION FORCE : 10KGf Max.(INITIAL)
 - WITHDRAWAL FORCE : 10KGf Max.(INITIAL)
 - LIFE TEST: 5,000 CYCLES MIN.
 - OTHER GENERAL SPEC. TO REFER "2BA1011-004210H SPEC";
 - TO CONFORM TO SINGATRON HAZARDOUS SUBSTANCE FREE SPEC.
 - GREEN PRODUCT IDENTIFICATION MARK ON JACK:
 - PRODUCT IDENTIFICATION LABEL ON PACKAGING: **RoHS**
 - PACKAGING: BAG

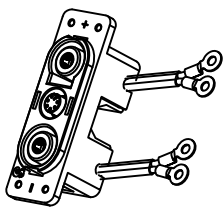
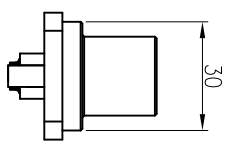
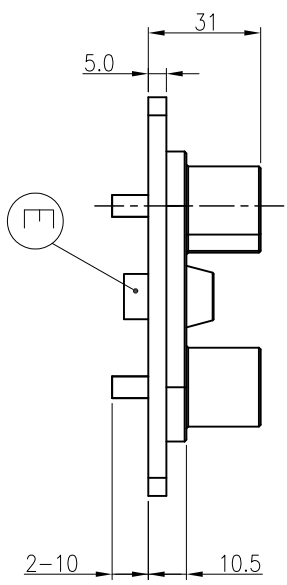
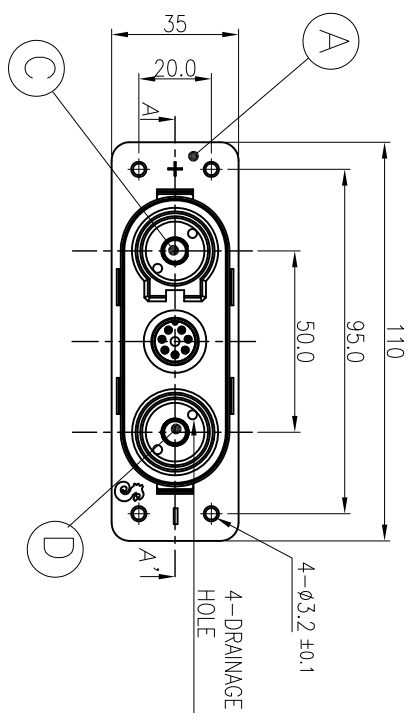
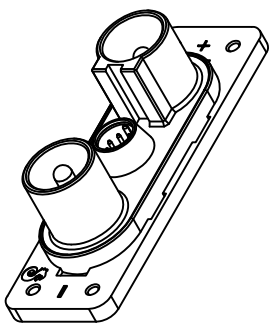

MATING PART
P/N : 2BA1010-003210H

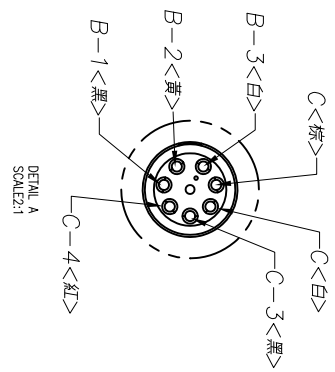
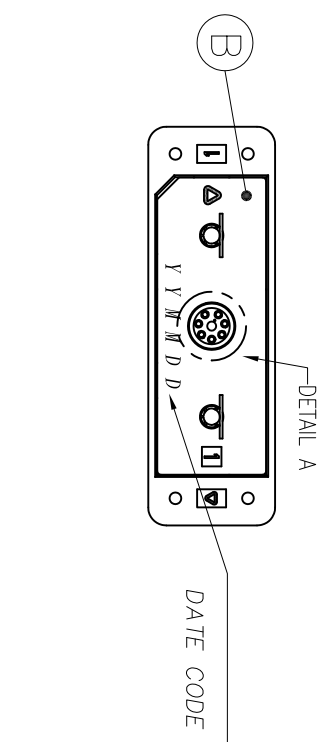

NO	DESCRIPTION	QTY	MATERIAL	PLATING & COLOR
E	7PIN CONNECTOR	1	COPPER ALLOY	GOLD PLATING
D	PIN(-)	1	COPPER ALLOY	SILVER PLATING
C	PIN(+)	1	COPPER ALLOY	SILVER PLATING
B	COVER	1	HIGH TEMP. THERMOPLASTIC UL 94V-0	BLACK COLOR
A	HOUSING	1	HIGH TEMP. THERMOPLASTIC UL 94V-0	BLACK COLOR

UNLESS OTHERWISE SPECIFIED TOLERANCES

DECIMALS:	ANGLES:	TITLE	BATTERY CONNECTOR+WIRE
X : ±0.5	X : ±2°	DWN	JASON 2011.10.25 PART NO.2BA1011-004210H
X.X : ±0.3	X.X : ±1'	CHKD	SCALED:1:1 UNIT: mm
X.XX : ±0.2		APVD	AMEBA 2011.10.25 SIZE: A3 SHEET:1 OF 1 REV: A

CUSTOMER COPY

Singatron Enterprise Co., Ltd.
信管企業股份有限公司