

REV. ECN NO OR DESCRIPTION	REVISED	DATE
A PRODUCT RELEASE	JASON	2011.03.01

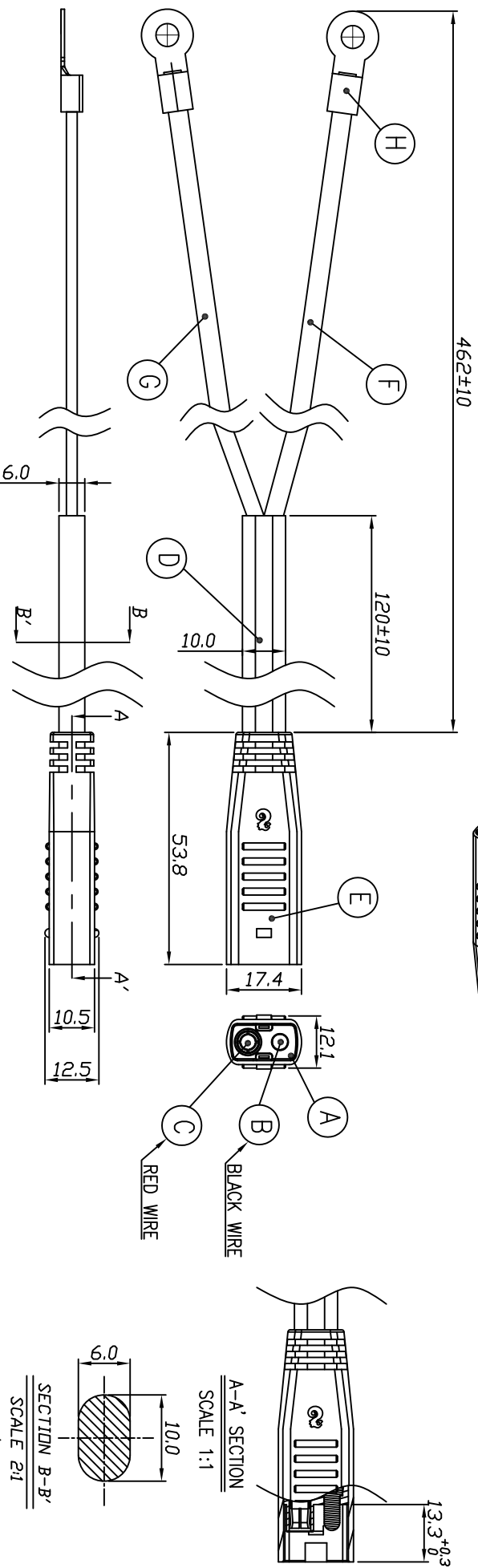
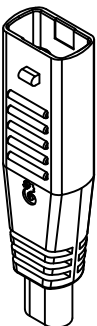

SPECIFICATIONS:

- 1. ELECTRICAL CHARACTERISTICS:**
 1-1. RATING: 36V DC 25A
 1-2. CONTACT RESISTANCE: 0.5mΩ MAX.(INITIAL PRE PIN)
 1-3. CONTACT RESISTANCE(WITH WIRE): 10mΩ MAX.(INITIAL)
- 2. MECHANICAL CHARACTERISTICS:**
 2-1. INSERTION FORCE : 3.0±2 KGF Max.(INITIAL)
 2-2. WITHDRAWAL FORCE :0.5 KGF Min.(INITIAL)
- 3. LIFE TEST: 3,000 CYCLES MIN.**
- 4. OTHER GENERAL SPEC. TO REFER "2BA1015-000210 SPEC".**
- 5. TO CONFORM TO SINGATRON HAZARDOUS SUBSTANCE FREE SPEC.**
- 6. GREEN PRODUCT IDENTIFICATION MARK ON JACK: ▲**
- 7. GREEN PRODUCT IDENTIFICATION LABEL ON PACKAGING: RoHS**
- 8. PACKAGING: BAG**
- 9. WATERPROOF RATE: IPX5**
- 10. CABLE JACKET MATERIAL:BLACK PVC**

規格:

- 1.電氣特性:**
 1-1. 額定功率 :36V 25A
 1-2. 接觸阻抗 :最大 0.5mΩ (單PIN初始值)
 1-3. 接觸阻抗 :最大10mΩ (含線初始值)
- 2.機械特性:**
 2-1 插入力 : 最大3.0 ±2 kgf (初始)
 2-2 拔出力 : 最小 0.5kgf(初始)
- 3.壽命測試: 最少3000次插拔**
- 4.其他規格參照"2BA1015-000210 規格書"**
- 5.產品符合Singatron 有害物質規範**
- 6.綠色產品標記號: ▲**
- 7.綠色包裝標識標記號: RoHS**
- 8.包裝方式:袋裝**
- 9.防水等級:IPX5**
- 10.線材絕緣材質:黑色PVC**

H	R-TERMINAL	2	OD 9.5 ID 5.3	TIN PLATING
G	WIRE	1	UL1015 #12 AWG	RED
F	WIRE	1		BLACK
E	INSERT MOLD	1	PVC	BLACK
D	OVER MOLD	1	PVC	BLACK
C	FEMALE PIN	1	BRASS	3u" GOLD PLATED OVER NICKEL PLATING
B	MALE PIN	1	BRASS	3u" GOLD PLATED OVER NICKEL PLATING
A	HOUSING	1	THERMOPLASTIC 94-V0	BLACK
NO	DESCRIPTION	QTY	MATERIAL	PLATING & COLOR
UNLESS OTHERWISE SPECIFIED TOLERANCES				
Singatron Enterprise Co., Ltd. 信音企業股份有限公司				
DECIMALS: ANGLES:				
X	:±0.5	X	:±2°	
X.X	:±0.3	X.X	:±1°	
X.XX	:±0.2			
TITLE: BATTERY CONNECTOR + WIRE				
DWN	JASON 2011.11.14	PART NO.	2BA1015-000210	
CHKD	ANNEAL 2011.11.15	SCALE	1:1	UNIT: mm
APVD	ANNEAL 2011.11.15	SIZE: A3	SHEET: 1 OF 1	REV: A
CUSTOMER COPY				

A 1 2 3 4 5 6 7 8

A 1 2 3 4 5 6 7 8