

REV.	ECN NO OR DESCRIPTION	REVISED	DATE
A	PRODUCT RELEASE	Duke	2014.12.30

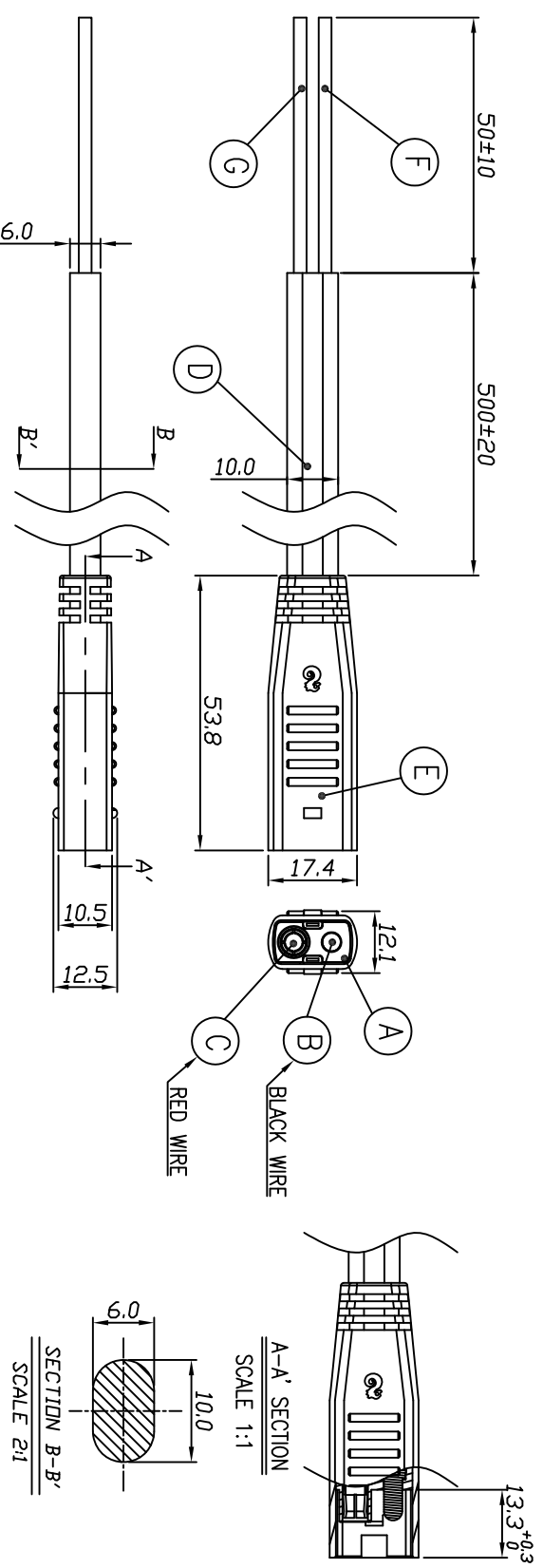
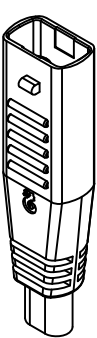

**SPECIFICATIONS:**

1. ELECTRICAL CHARACTERISTICS:
  - 1-1. RATING: 36V DC 25A
  - 1-2. CONTACT RESISTANCE: 0.5mΩ MAX (INITIAL PRE PIN)
  - 1-3. CONTACT RESISTANCE(WITH WIRE): 10mΩ MAX.(INITIAL)
2. MECHANICAL CHARACTERISTICS:
  - 2-1. INSERTION FORCE : 3.0±2 KGf Max.(INITIAL)
  - 2-2. WITHDRAWAL FORCE :0.5 KGf Min.(INITIAL)
3. LIFE TEST: 3,000 CYCLES MIN.
4. OTHER GENERAL SPEC. TO REFER "2BA1015-W01210H SPEC".
5. TO CONFORM TO SINGAITRON HAZARDOUS SUBSTANCE FREE SPEC.
6. GREEN PRODUCT IDENTIFICATION MARK ON JACK:
7. GREEN PRODUCT IDENTIFICATION LABEL ON PACKAGING:
8. PACKAGING: BAG
9. WATERPROOF RATE: IPX5
10. CABLE JACKET MATERIAL:BLACK PVC

**規格:**

- 1.電氣特性:
  - 1-1. 額定功率 :36V 25A
  - 1-2. 接觸阻抗 :最大 0.5mΩ (單PIN初始值)
  - 1-3. 接觸阻抗 :最大 10mΩ (含線初始值)
- 2.機械特性:
  - 2-1 插入力 : 最大3.0±2 kgf (初始)
  - 2-2 拔出力 : 最小 0.5kgf (初始)
- 3.壽命測試: 最少3000次插拔
- 4.其他規格參照 "2BA1015-W01210H 規格書"
- 5.產品符合 Singatron 有害物質規範
- 6.綠色產品標記號:
- 7.綠色包裝標識不標識:
- 8.包裝方式:袋裝
- 9.防水等級:IPX5
- 10.線材絕緣材質:黑色PVC

G	WIRE	1	UL1015 #14 AWG	RED
F	WIRE	1		BLACK
E	INSERT MOLD	1	PVC	BLACK
D	OVER MOLD	1	PVC	BLACK
C	FEMALE PIN	1	BRASS	3u" GOLD PLATED OVER NICKEL PLATING
B	MALE PIN	1	BRASS	3u" GOLD PLATED OVER NICKEL PLATING
A	HOUSING	1	THERMOPLASTIC 94-V0	BLACK
NO	DESCRIPTION	QTY	MATERIAL	PLATING & COLOR
UNLESS OTHERWISE SPECIFIED TOLERANCES				
DECIMALS:		ANGLES:		
X	:±0.5	X	:±2°	
X.X	:±0.3	X.X	:±1'	
X:XX	:±0.2			
TITLE		BATTERY CONNECTOR + WIRE		
DWN	Due	PART NO.2BA1015-W01210H		
CHKD		SCALE	1:1	UNIT: mm
APVD	MEM	SIZE:	A3	SHEET:1 OF 1
REV: A				
CUSTOMER COPY				

Singatron Enterprise Co., Ltd.  
 信晉企業股份有限公司