

REV.	ECN NO OR DESCRIPTION	REVISED	DATE
A	PRODUCT RELEASE	JASON	2011.07.04

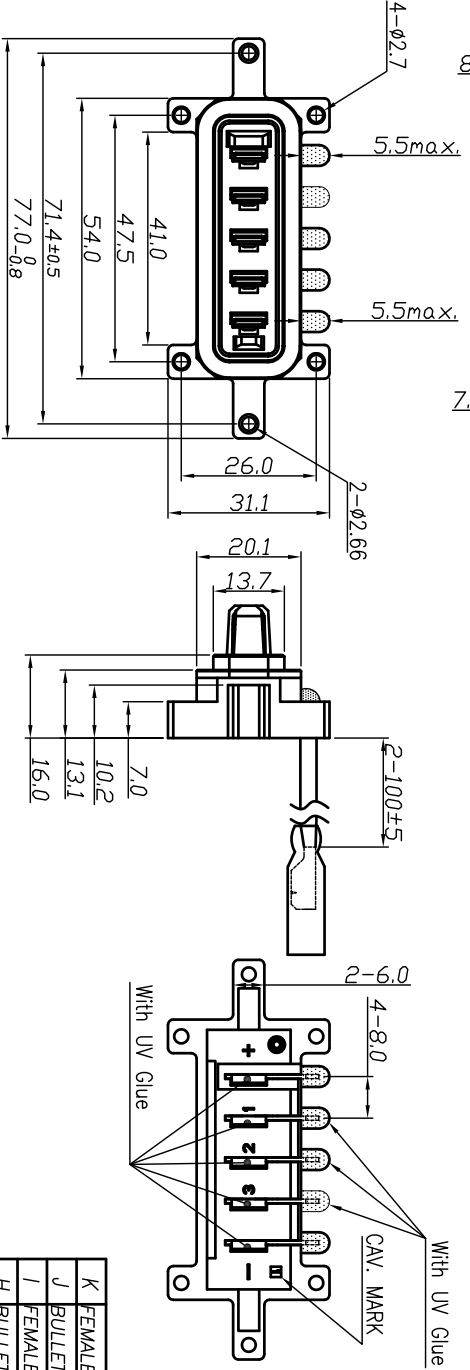
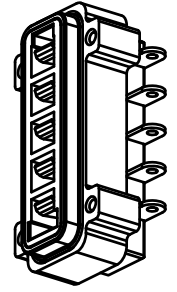
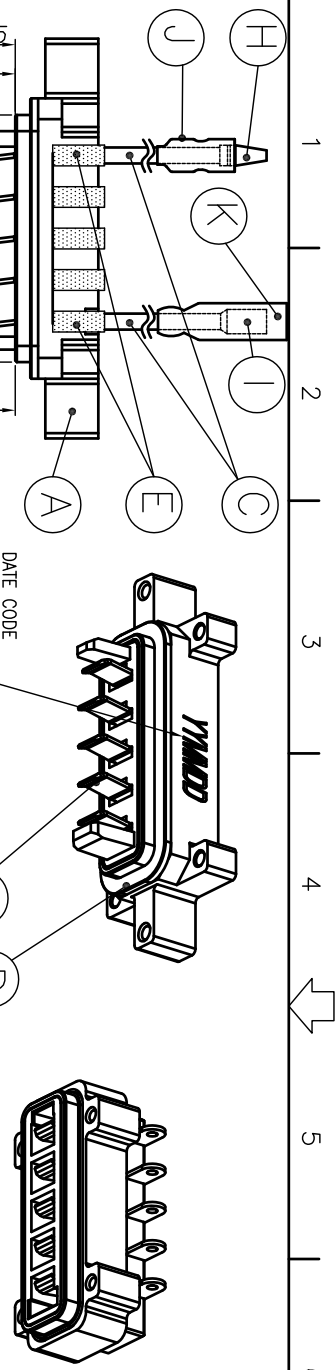

BATTERY CONNECTOR
DETECT PIN

WIRE DIAGRAM

RED (UL1015 16AWG)
BLACK (UL1015 16AWG)



K	FEMALE TUBE(WST)	1	PVC(P10501M35)	N/A
J	BULLET TUBE(WST)	1	PVC(P00501M35)	N/A
I	FEMALE TERMINAL(WST)	1	BRASS(A10505BS-2)	TIN PLATING
H	BULLET TERMINAL(WST)	1	BRASS(A00501BS-2)	TIN PLATING
G	SELF-TAPPING SCREW	2	SUS M3 L=10.0	N/A
F	SCREW (NYLON)	4	SUS M2.5X0.45 L=10.0	N/A
E	HEAT SHRINK TUBE	2	φ6.0 L=20.0	BLACK COLOR
D	GASKET	1	SILICON	BLACK COLOR
C	WIRE	1	UL1015 #16	RED COLOR
B	SPRING	1	UL1015 #16	BLACK COLOR
A	HOUSING	5	COPPER ALLOY 0.8t	SILVER PLATING
NO	DESCRIPTION	QTY	MATERIAL	PLATING & COLOR

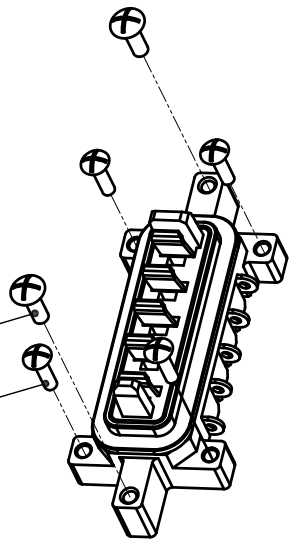

RoHS

- SPECIFICATIONS:**
- ELECTRICAL CHARACTERISTICS:**
 - 1-1. RATING: 40V DC 20A
 - 1-2. CONTACT RESISTANCE: 2.0m Ω MAX.(INITIAL WITHOUT WIRE)
 - MECHANICAL CHARACTERISTICS:**
 - 2-1. INSERTION FORCE : 5.0 ± 2KGF (INITIAL)
 - 2-2. WITHDRAWAL FORCE : 6.0 ± 2KGF (INITIAL)
 - LIFE TEST: 3,000 CYCLES MIN.
 - OTHER GENERAL SPEC. TO REFER "2BA1016-000210 SPEC."
 - TO CONFORM TO SINGATRON HAZARDOUS SUBSTANCE FREE SPEC.
 - GREEN PRODUCT IDENTIFICATION MARK ON JACK:
 - PRODUCT IDENTIFICATION LABEL ON PACKAGING:
 - PACKAGING: BAG
 - WATERPROOF RATE: IP67
 - PART NO. F.G SHIPPING WITH BAG

DECIMALS:	ANGLES:	TITLE	SCALE	UNIT:	SHEET:	REV:
X : ±0.5	X : ±2°	BATTERY CONNECTOR+WIRE	1:2	mm	1 OF 1	A
X.X : ±0.3	X.X : ±1°					
X.XX : ±0.2						

CUSTOMER COPY

Singatron Enterprise Co., Ltd.
信益企業股份有限公司