

REV.	ECN NO. OR DESCRIPTION	REVISED	DATE
A	PRODUCT RELEASE	JASON	2011.07.11
B	ECN NO. T110019	JASON	2011.07.25

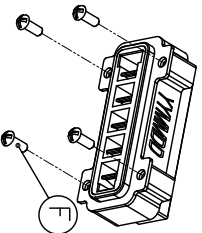
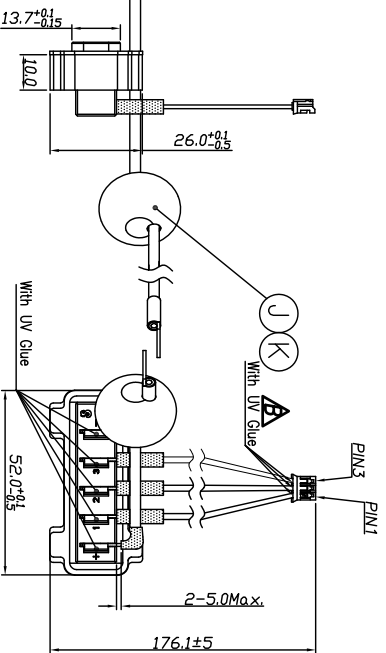
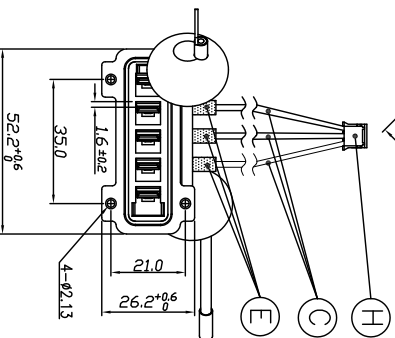
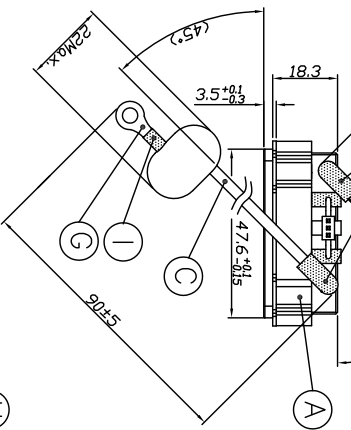
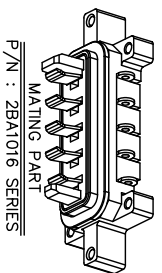
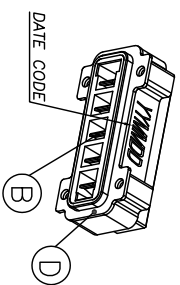

- SPECIFICATIONS:**
- ELECTRICAL CHARACTERISTICS:**
    - 1-1. RATING: 40V DC 20A
    - 1-2. (+) CONTACT RESISTANCE: 10m Ω MAX (INITIAL)
    - 1-3. (-) CONTACT RESISTANCE: 10m Ω MAX (INITIAL)
    - 1-4. SIGNAL CONTACT RESISTANCE: 35mΩ MAX (INITIAL)
  - MECHANICAL CHARACTERISTICS:**
    - 2-1. INSERTION FORCE: 3.0 ± 0.2 KGf (INITIAL)
    - 2-2. WITHDRAWAL FORCE: 8.0 ± 2.0 KGf (INITIAL)
  - LIFE TEST:** 3,000 CYCLES MIN.
  - OTHER GENERAL SPEC.** TO REFER 2BA1017-001210 SPEC.
  - TO CONFORM TO SINGATRON HAZARDOUS SUBSTANCE FREE SPEC.**
  - GREEN PRODUCT IDENTIFICATION MARK ON JACK:**
  - PRODUCT IDENTIFICATION LABEL ON PACKAGING:** **RoHS**
  - PACKAGING:** BAG
  - WATERPROOF RATE:** IP67
  - PART NO. F SHIPPING WITH BAG**
  - EXCLUDE PART NO. J IN SALT WATER SPRAY TEST**

WIRE DIAGRAM	DETECT PIN CONNECTOR
SPRING(+)	RED (UL1015 16AWG)
SPRING(-)	BLACK (UL1015 16AWG)
SIGNAL(1)	BROWN (UL1007 22AWG)
SIGNAL(2)	WHITE (UL1007 22AWG)
SIGNAL(3)	YELLOW (UL1007 22AWG)

NO	DESCRIPTION	QTY	MATERIAL	PLATING & COLOR
L	HEAT SHRINK TUBE	2	Ø8.0 L=20mm	BLACK COLOR
K	HEAT SHRINK TUBE	2	Ø18.0 L=20mm	BLACK COLOR
J	EMI CORE	2	KING CORE:K5B T14.5x8x10.2	BLACK COLOR
I	HEAT SHRINK TUBE	2	Ø4.0 L=15.0	BLACK COLOR
H	CONNECTOR	3	TER-PHOSPHOR BRONZE	TIN-PLATED
G	R-TERMINAL	2	HSG:NYLON UL94V-0	WHITE COLOR
F	SELF-TAPPING SCREW	4	OD:8.0 ID:4.3 L:15.6	N/A
E	HEAT SHRINK TUBE	3	SUS M2.6 L=8	N/A
D	GASKET	1	Ø4.0 L=20mm	BLACK COLOR
C	WIRE	3	SILICON SHORE A 70'	BLACK COLOR
B	SPRING	2	UL1007 #22	SEE WIRE DIAGRAM
A	HOUSING	5	UL1015 #16	SEE WIRE DIAGRAM
NO	DESCRIPTION	1	COPPER ALLOY 0.8t	SILVER PLATING
NO	DESCRIPTION	1	THERMOPLASTIC	BLACK COLOR

UNLESS OTHERWISE SPECIFIED TOLERANCES

DECIMALS: ANGLES:

X : ±0.5 X : ±2°  
 X.X : ±0.3 X.X : ±1°  
 X.XX : ±0.2

TITLE	BATTERY CONNECTOR+WIRE
DWN	2011.8.10
CHKD	2011.8.10
APVD	2011.8.10
PART NO.	2BA1017-001210
SCALE:	1:1
SIZE:	A3
SHEET:	1 OF 1
REV:	B

CUSTOMER COPY

Singatron Enterprise Co., Ltd.  
 信登企業股份有限公司