

REV.	ECN NO OR DESCRIPTION	REVISED	DATE
A	PDR RELEASE	IVY-C	2015.04.13

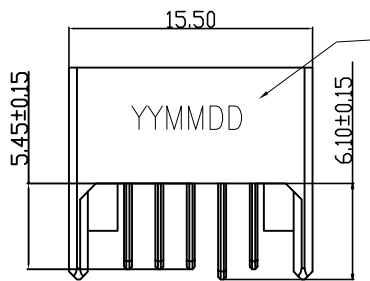

Ⓔ
D/C
yy:
mm:
dd:

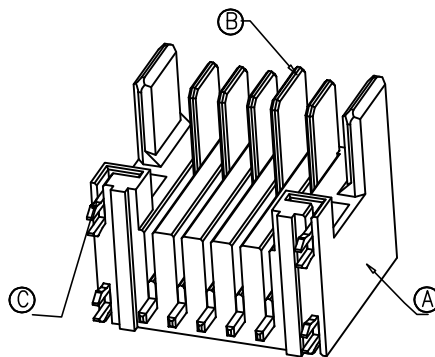

SPECIFICATIONS:

- VOLTAGE RATING: 30V DC MAX.
- CURRENT RATING: 7.0 Amps, MAX. PER CONTACT
- CONTACT RESISTANCE: 20mΩ (INITIAL)MAX.
- INSULATION RESISTANCE: 1000MΩ MIN. AT 500V DC.
- WITHSTANDING VOLTAGE: 500V AC MIN./1 MINUTE.
- LIFE TEST: 5,000 CYCLES.
- TO CONFORM TO THE SINGATRON HAZARDOUS SUBSTANCE FREE SPEC.
- HALOGEN FREE PRODUCT IDENTIFICATION LABEL ON PACKAGING:
- OPERATING TEMPERATURE: -40°C TO +85°C.
- PACKAGE: SEE "2BA1528 SERIES" PACKAGE.
- FOR REFLOW SOLDERING LEAD-FREE PROCESS.
- OTHER GENERAL SPEC. TO REFER "2BA1528 SERIES SPEC"

PART NO.

2BA1528-000111F

- SUFFIX: HALOGEN FREE
- PACKAGE
1: TRAY
- HOUSING COLOR
1: BLACK
- CONTACT PLATING
1: Au 3u" MIN ON CONTACT AREA,
MATTE TIN PLATED ON SOLDER AREA
50u" NICKEL UNDERPLATING OVERALL.

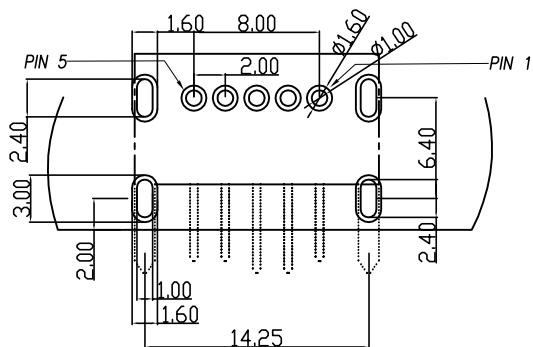
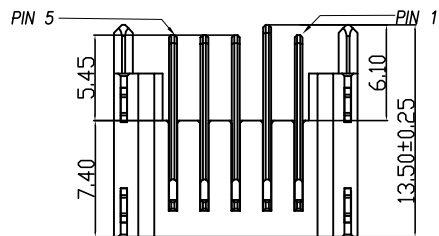
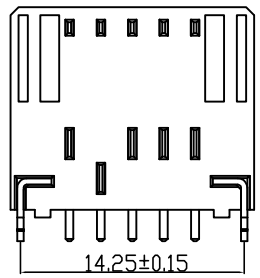
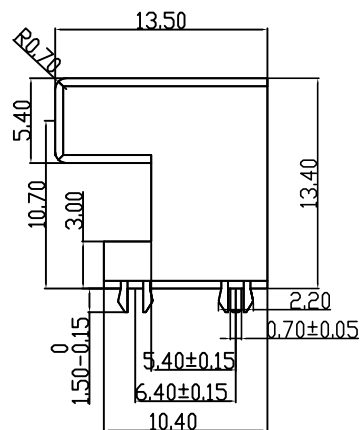
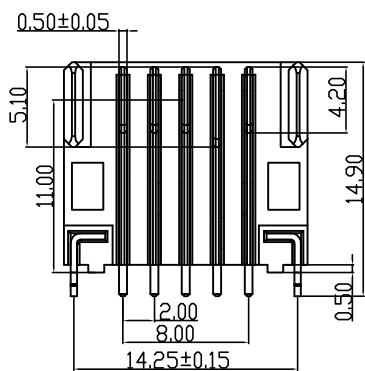

RECOMMENDED P.C.B LAYOUT
P.C.B THICKNESS=1.6mm

D	INK	-	INK	BLACK
C	FORK	4	COPPER ALLOY	MATTE TIN 50u" MIN
B	CONTACT	5	COPPER ALLOY	SEE PART NO.
A	HOUSING	1	HIGH TEMP. THERMOPLASTIC UL 94V-0	BLACK

NO	DESCRIPTION	QTY	MATERIAL	PLATING & COLOR
UNLESS OTHERWISE SPECIFIED TOLERANCES		Singatron Enterprise Co., Ltd. 信音企業股份有限公司		

DECIMALS:	ANGLES:	TITLE	2.00mm PITCH BATTERY CONN	
X :±0.5	X :±2°	DWN	IV-C 2015.04.13	PART NO. 2BA1528-000111F
X.X :±0.3	X.X :±1°	CHKD	ANGEL2015.04.13	SCALE 3:1 UNIT: mm
X.XX :±0.2		APVD	ANGEL2015.04.13	SIZE: A3 SHEET:1 OF 1 REV: A

CUSTOMER COPY