

THE HEIGHT OF THE EPOXY AB GLUE
SOLIDIFICATION AFTER 1.50 mm Max.

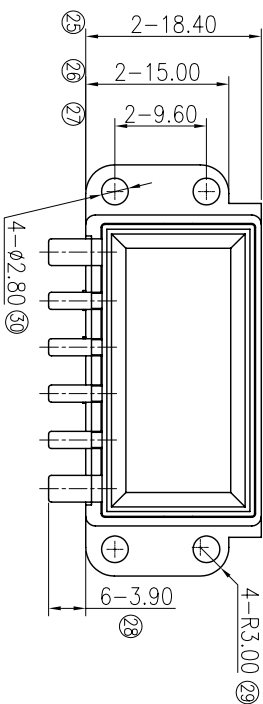

- SPECIFICATIONS:
- ELECTRICAL CHARACTERISTICS:
 - RATING CURRENT: 30A
 - RATING VOLTAGE: 220V AC.
 - CONTACT RESISTANCE: 30mΩ(INITIAL), 50mΩ(AFTER LIFE TEST)
 - DIELECTRIC WITHSTANDING VOLTAGE: 500 VAC FOR ONE MINUTE.
 - INSULATION RESISTANCE: 1,000MΩ MIN. AT 500 VDC
 - MECHANICAL CHARACTERISTICS:
 - INSERTION FORCE: 6N~60N.
 - WITHDRAWAL FORCE: 6N~60N.
 - LIFE TEST: 5,000 CYCLES.
 - ENVIRONMENTAL CHARACTERISTICS:
 - OPERATING TEMPERATURE: -30°~+80°
 - TO CONFORM TO SINGATRON HAZARDOUS SUBSTANCE FREE SPEC.
 - RoHS COMPLIANT PRODUCT.
 - HALOGEN FREE PRODUCT IDENTIFICATION MARK: (C)
 - HALOGEN FREE PRODUCT IDENTIFICATION LABEL ON PACKAGING: (C)
 - OTHER GENERAL SPEC. TO REFER "2BA205X SERIES SPEC"
 - FAI NO. MARK: (F)
 - PACKAGING: TRAY.

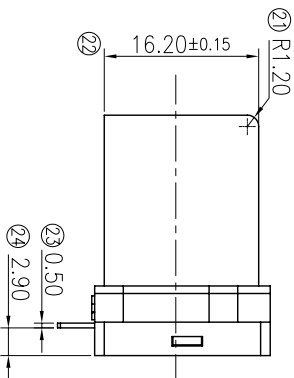
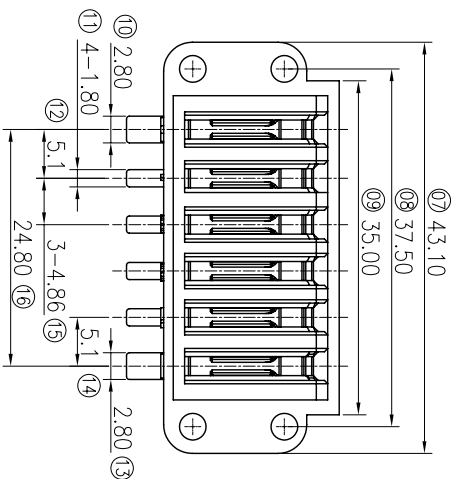
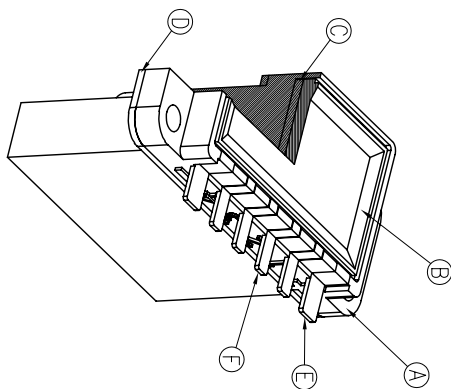
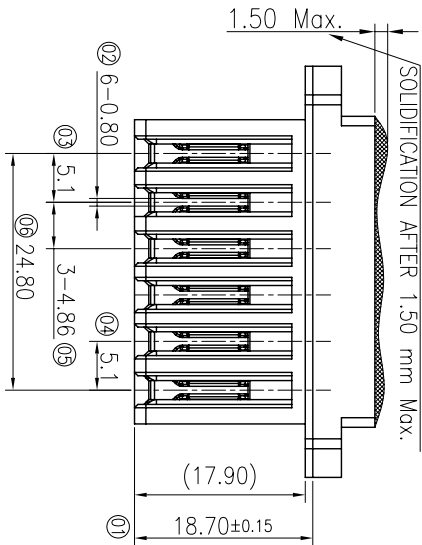

REV: ECN NO. OR DESCRIPTION	REVISED	DATE
A	PRODUCT RELEASE	Junkang 2018.11.05

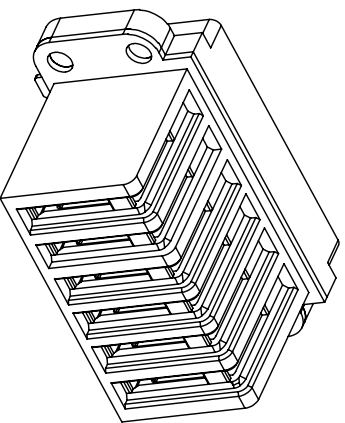
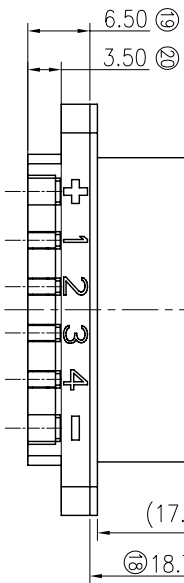

NO.	DESCRIPTION	QTY.	MATERIAL	PLATING & COLOR
A	BODY	1	PBT+15%GF, UL94 V-0	BLACK
B	COVER	1	PBT+15%GF, UL94 V-0	BLACK
C	GASKET-A	1	SILICONE 50P	RED
D	GASKET-B	1	SILICONE 50P	RED
E	TERMINAL-A	2	BRASS 0.5T	NICKEL PLATING
F	TERMINAL-B	4	BRASS 0.5T	

UNLESS OTHERWISE SPECIFIED TOLERANCES

Singatron Enterprise Co., Ltd.
信登企業股份有限公司

DECIMALS: ANGLES:

X : ±1.00 X : ±2°

XX : ±0.50 XX : ±1°

XXX : ±0.30

X,XXX : ±0.20

TITLE	BATTERY FEMALE CONNECTOR
DWN	18/11/7
CHKD	18/11/7
APVD	18/11/7
PART NO.:	2BA2051-W06M00F
SCALE:	FREE UNIT: mm
SIZE:	A3
SHEET:	10F1 REV: A

CUSTOMER COPY