

REV.	ECN NO.	OR DESCRIPTION	REVISED	DATE
A		PRODUCT RELEASE	Junkang	2018.11.05
B	ECN NO.:C2022203-R02		Ziwei.Wu	2022.05.11

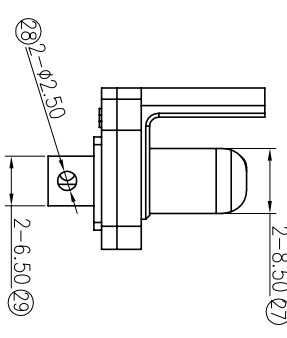

- SPECIFICATIONS:
- ELECTRICAL CHARACTERISTICS:
 - 1-1. RATING CURRENT: 30A
 - 1-2. RATING VOLTAGE: 30V DC. Δ
 - 1-3. CONTACT RESISTANCE: 30m Ω (INITIAL), 50m Ω (AFTER LIFE TEST)
 - 1-4. DIELECTRIC WITHSTANDING VOLTAGE: 500 VAC FOR ONE MINUTE.
 - 1-5. INSULATION RESISTANCE: 1,000M Ω MIN. AT 500 VDC
 - MECHANICAL CHARACTERISTICS:
 - 2-1. INSERTION FORCE: 6N~60N.
 - 2-2. WITHDRAWAL FORCE: 6N~60N.
 - 2-3. LIFE TEST: 5,000 CYCLES.
 - ENVIRONMENTAL CHARACTERISTICS:
 - 3-1. OPERATING TEMPERATURE: -30°C~+80°C
 - 3-2. TO CONFORM TO SINGATRON HAZARDOUS SUBSTANCE FREE SPEC.
 - 3-3. RoHS COMPLIANT PRODUCT.
 - 3-4. HALOGEN FREE PRODUCT IDENTIFICATION MARK $\text{\textcircled{C}}$
 - 3-5. HALOGEN FREE PRODUCT IDENTIFICATION LABEL ON PACKAGING $\text{\textcircled{E}}$
 - 3-6. THE ORIGINAL CUSTOMER USES A TEMPERATURE RISE OF 55°C $\text{\textcircled{A}}$
 - OTHER GENERAL SPEC. TO REFER "2BA205X SERIES SPEC"
 - FAI NO. MARK: $\text{\textcircled{D}}$
 - PACKAGING: TRAY.

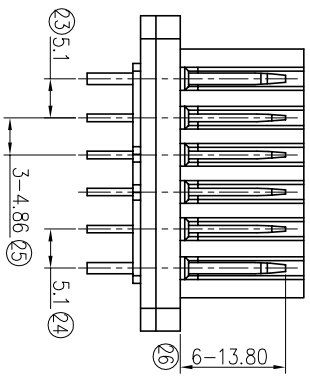
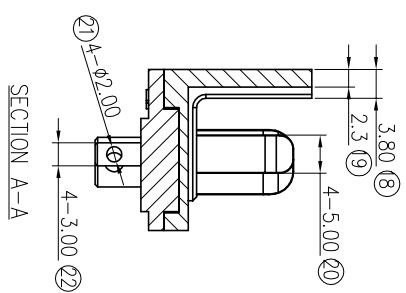
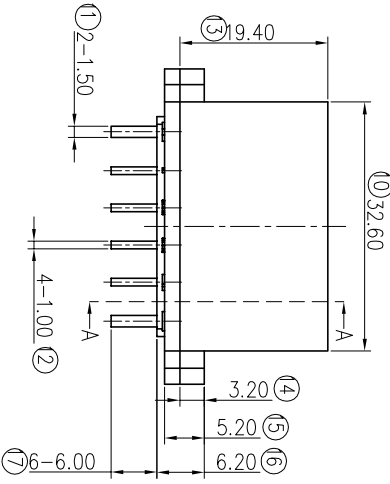
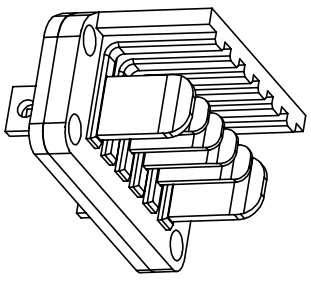
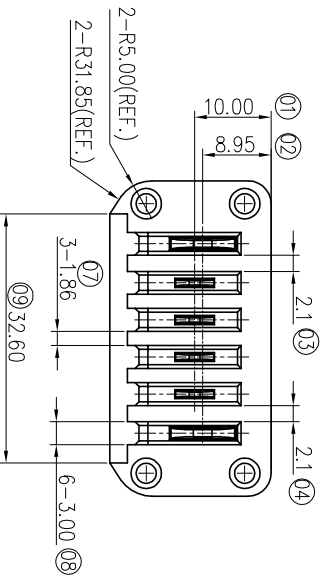
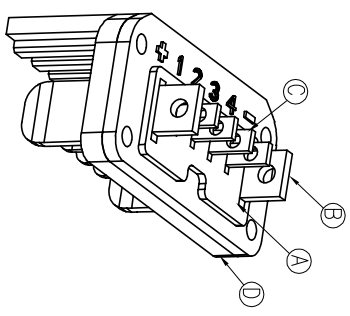
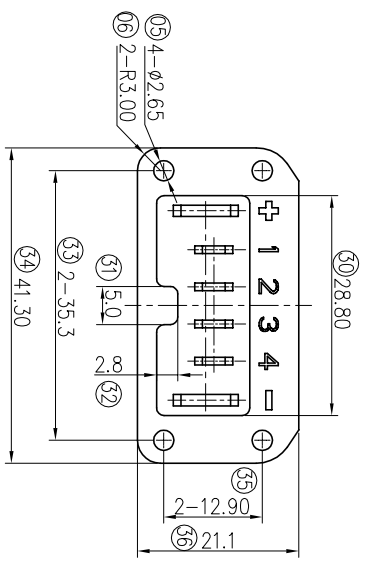

NO.	DESCRIPTION	QTY.	MATERIAL	PLATING & COLOR
A	BODY	1	PBT+15%GF, UL94 V-0	BLACK
B	TERMINAL-A	2	BRASS 1.5T	NICKEL PLATING
C	TERMINAL-B	4	BRASS 1.0T	NICKEL PLATING
D	RUBBER	1	SILICONE 50P	BLACK

UNLESS OTHERWISE SPECIFIED TOLERANCES

Singatron Enterprise Co., Ltd.
信音企業股份有限公司

TITLE: BATTERY CONNECTOR 180 ANGLE PLUG

DWN: Ziwei.Wu PART NO.: 2BA2052-W06M00F

CHKD: Qicai.Hu SCALE: 1:1 UNIT: mm

APVD: Jim-deng SIZE: A3 SHEET: 10F1 REV: B

X:XXX:±0.30

X:XXX:±0.20

CUSTOMER COPY