

REV.	ECN NO.	OR DESCRIPTION	REVISED	DATE
A		PRODUCT RELEASE	Junkang	2018.11.05
B	ECN NO.: C2022203-R02	Zwei.Wu		2022.05.11

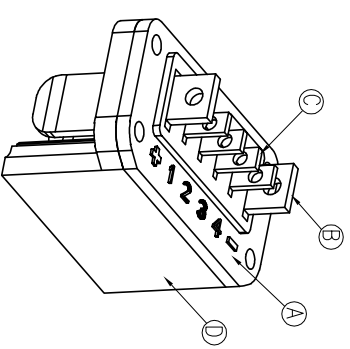
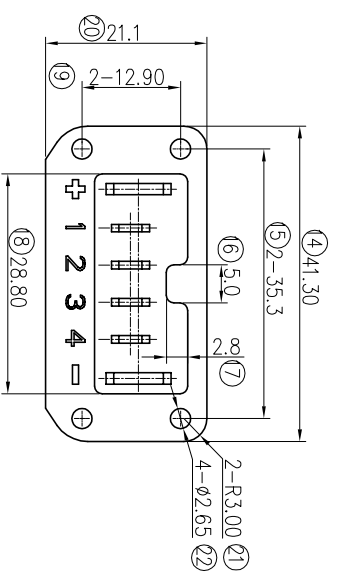
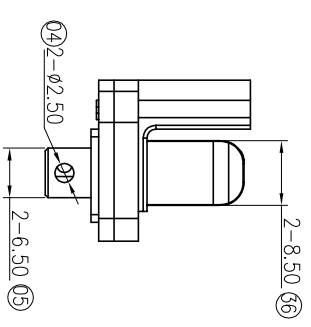
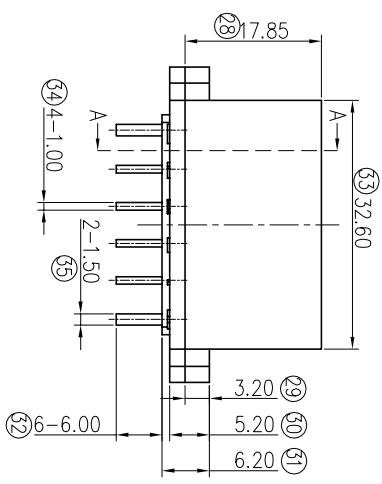
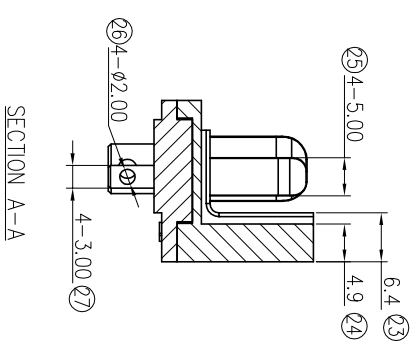
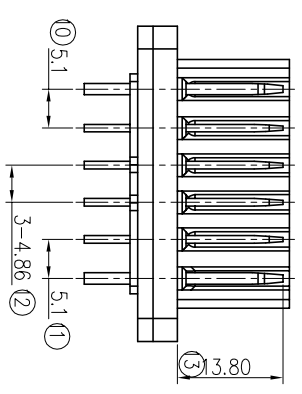
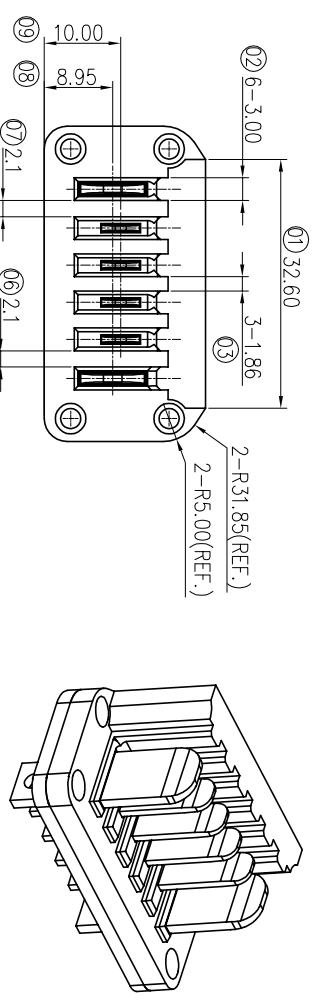

- SPECIFICATIONS:
- ELECTRICAL CHARACTERISTICS:
    - RATING CURRENT: 30A
    - RATING VOLTAGE: 30V DC  $\Delta$
    - CONTACT RESISTANCE: 30m $\Omega$ (INITIAL), 50m $\Omega$ (AFTER LIFE TEST)
    - DIELECTRIC WITHSTANDING VOLTAGE: 500 VAC FOR ONE MINUTE.
    - INSULATION RESISTANCE: 1,000M $\Omega$  MIN. AT 500 VDC
  - MECHANICAL CHARACTERISTICS:
    - INSERTION FORCE: 6N~60N.
    - WITHDRAWAL FORCE: 6N~60N.
    - LIFE TEST: 5,000 CYCLES.
  - ENVIRONMENTAL CHARACTERISTICS:
    - OPERATING TEMPERATURE: -30 $^{\circ}$ C~+80 $^{\circ}$ C
    - TO CONFORM TO SINGATRON HAZARDOUS SUBSTANCE FREE SPEC.
    - RoHS COMPLIANT PRODUCT.
    - HALOGEN FREE PRODUCT IDENTIFICATION MARK  $\odot$
    - HALOGEN FREE PRODUCT IDENTIFICATION LABEL ON PACKAGING
    - THE ORIGINAL CUSTOMER USES A TEMPERATURE RISE OF 55 $^{\circ}$ C/ $\Delta$
  - OTHER GENERAL SPEC. TO REFER "2BA205X SERIES SPEC"
  - FAI NO. MARK  $\text{\textcircled{A}}$
  - PACKAGING: TRAY.

NO.	DESCRIPTION	QTY.	MATERIAL	PLATING & COLOR
A	BODY	1	PBT+15%GF, UL94 V-0	BLACK
B	TERMINAL-A	2	BRASS 1.5T	NICKEL PLATING
C	TERMINAL-B	4	BRASS 1.0T	NICKEL PLATING
D	RUBBER	1	SILICONE 50P	BLACK

UNLESS OTHERWISE SPECIFIED TOLERANCES

Singatron Enterprise Co., Ltd.  
信音企業股份有限公司

TITLE: BATTERY CONNECTOR 90 ANGLE PLUG

DWN: Zwei.Wu PART NO.: 2BA2053-W06M00F

CHKD: Qicoi.Hu SCALE: 1:1 UNIT: mm

APVD: Jim-deng SIZE: A3 SHEET: 10F1 REV: B

X:XXX:  $\pm 0.20$

CUSTOMER COPY