

REV./ECN NO.	OR DESCRIPTION	REVISED	DATE
A	NEW RELEASE	ZW	04/10'12

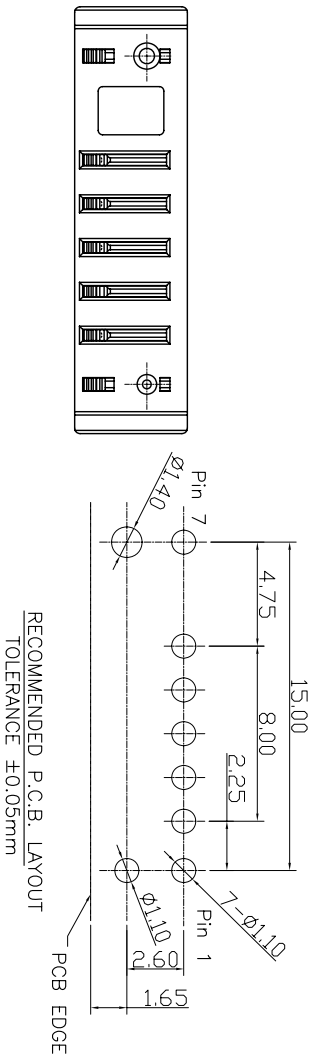

SPECIFICATIONS:

- ELECTRICAL CHARACTERISTICS:
 - 1-1. RATING: 30V, 7A MAX.
 - 1-2. CONTACT RESISTANCE: 20 MILLIOHMS MAX. FOR INITIAL, BY 500V DC AFTER 1 MINUTE.
 - 1-3. INSULATION RESISTANCE: 100 MEGAOHMS MIN.
 - 1-4. DIELECTRIC WITHSTANDING VOLTAGE: 500V RMS AFTER 1 MINUTE.
- MECHANICAL CHARACTERISTICS:
 - 2-1. INSERTION FORCE : 0.18~1.5 KGF
 - 2-2. WITHDRAWAL FORCE : 0.15~1.2 KGF
- LIFE TEST: 5,000 CYCLES MIN.
- TEMPERATURE RANGE:-40~+85°C
- OTHER GENERAL SPEC. TO REFER "2BA2Y08 SERIES SPEC."
- TO CONFORM TO SINGATRON HAZARDOUS SUBSTANCE FREE SPEC.
- HALOGEN FREE PRODUCT IDENTIFICATION LABEL ON PACKAGING:
- PACKAGING: TARY
- PART NO. 2BA2Y08 - 0 0 0 1 1 2 F

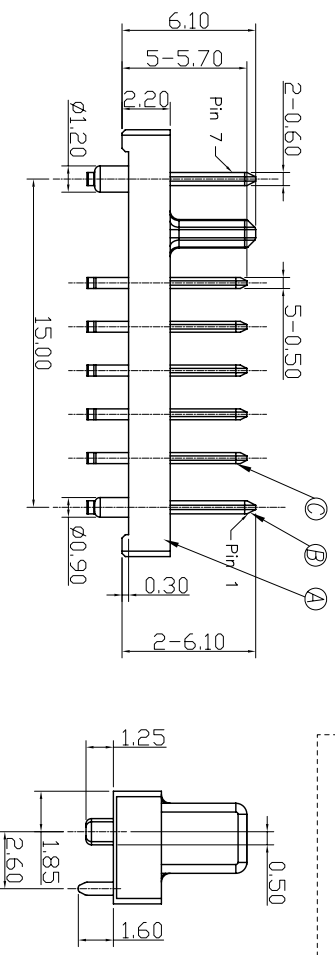
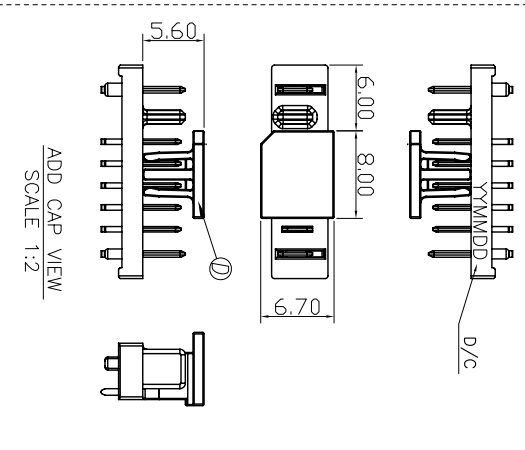
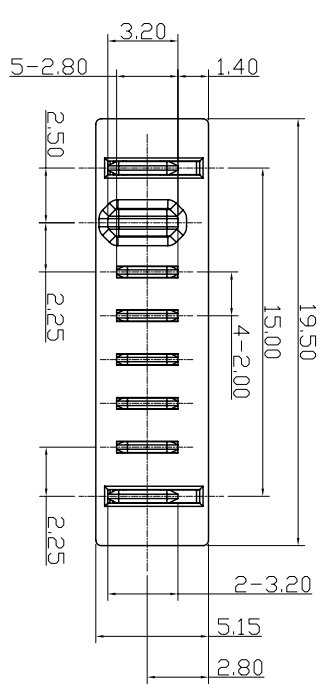

HOUSING MATERIAL: HIGH THERMOPLASTIC
 0=HI-TEMP THERMOPLASTIC
 CONTACT PLATING: 00=GOLD FLASH
 LIFE TEST CYCLE: 1=5000 CYCLES
 CAP: 1=WITH CAP

D	CAP	1	HIGH THERMOPLASTIC UL 94V-0	BLACK COLOR
C	TERMINAL 2	5	COPPER ALLOY	GOLD FLASH PLATING OVER NICKEL
B	TERMINAL 1	2	COPPER ALLOY	GOLD FLASH PLATING OVER NICKEL
A	HOUSING	1	HIGH THERMOPLASTIC UL 94V-0	BLACK COLOR
NO	DESCRIPTION	QTY	MATERIAL	PLATING & COLOR

UNLESS OTHERWISE SPECIFIED TOLERANCES:
 DECIMALS: ANGLES:
 X : ±0.5 X : ±2°
 X.X : ±0.3 X.X : ±1'
 X.XX : ±0.2

TITLE	7P BATTERY CONN		
DWN	ZW	PART NO.	2BA2Y08-000112F
CHKD	KIM	SCALE N/A	UNIT: mm
APVD	SEAN	SIZE: A4	SHEET: 10F1
REV.: A			

Singatron Enterprise Co., Ltd.
 信音企業股份有限公司

CUSTOMER COPY