

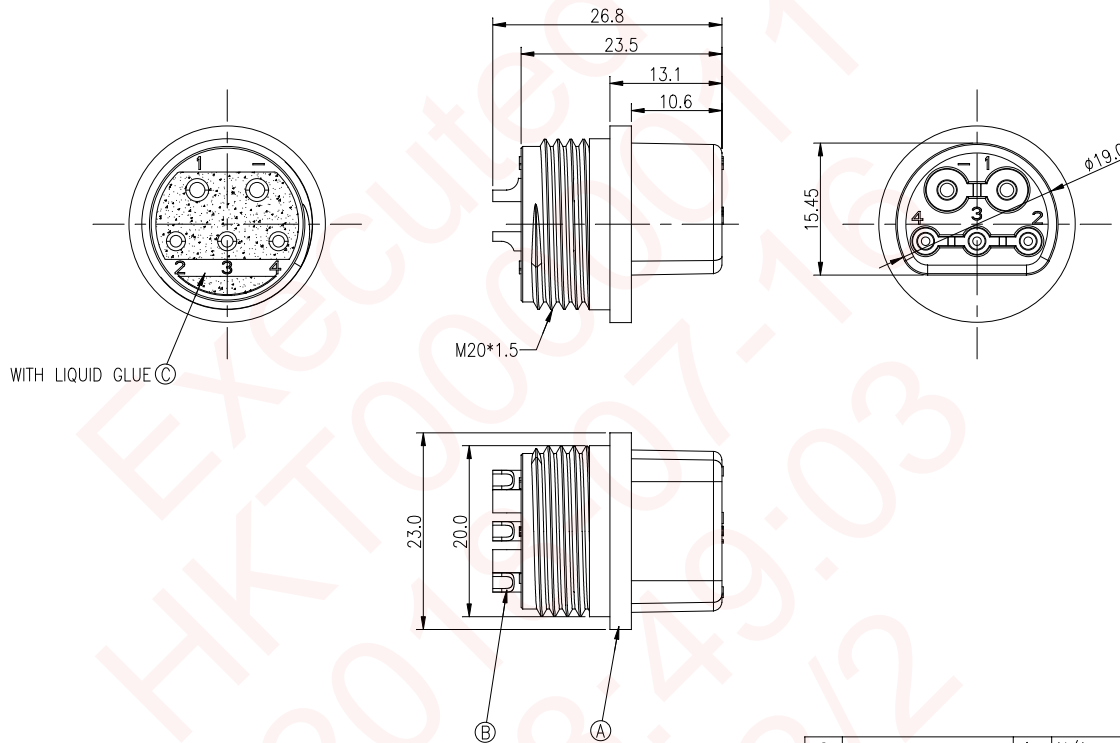

REV.	ECN NO OR DESCRIPTION	REVISED	DATE
A	PDR NO.:A171215-1A	JF	2018.01.15



NOTES:

- TEST CONDITIONS:
2-1. CONDUCTANCE RESISTANCE 20m Ohm Max.
2-2. HI-POT TEST 500VAC,0.5mA(1SEC)
2-3. INSULATION RESISTANCE: 100M Ohm Min. BY 500 VDC
- SPECIFICATIONS:SEE "BA SERIES SPECIFICATIONS".
- TO CONFORM TO SINGATRON HAZARDOUS SUBSTANCE FREE SPEC.
- GREEN PRODUCT IDENTIFICATION LABEL ON PACKAGING: 

C	LIQUID GLUE	1	N/A	BLACK
B	MALE PIN	5	C3604	1~3GOLD PLATING OVER NICKEL PLATING
A	FEMALE BODY	1	PA66+GF(A63V0GV25)	BLACK
NO	DESCRIPTION	QTY	MATERIAL	PLATING & COLOR
UNLESS OTHERWISE SPECIFIED TOLERANCES		 Singatron Enterprise Co., Ltd. 信音企業股份有限公司		
DECIMALS: X :±0.30 X.X :±0.20 X.XX :±0.10 X.XXX :±0.05		ANGLES: X :±1° X.X :±0.5°		TITLE BATTERY CONNECTOR(IP67) FEMALE CONN. MALE (2+3)PIN(10+5A) DWN JF PART NO.2BA3030-V05801H CHKD Jun SCALE 2:1 UNIT: mm APVD Steve SIZE: A3 SHEET:1 OF 1 REV: A
CUSTOMER COPY				