

REV.	ECN NO OR DESCRIPTION	REVISED	DATE
A	PDR NO: T130322-7B	Springwu	2015.03.10

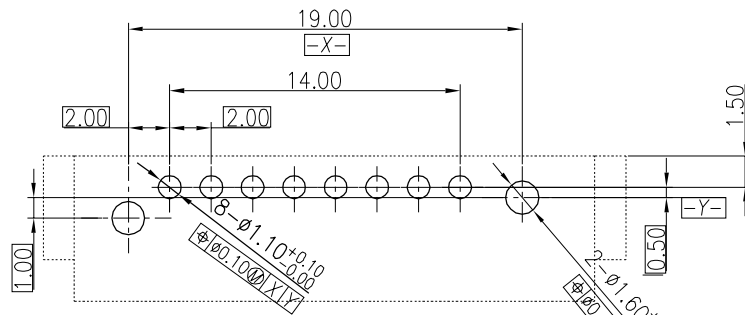

RECOMMENDED P.C.B LAYOUT(TOP VIEW)
TOLERANCE ±0.05mm(T=1.20mm)

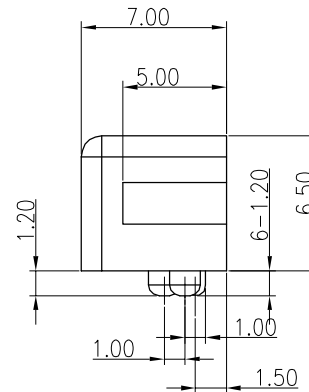
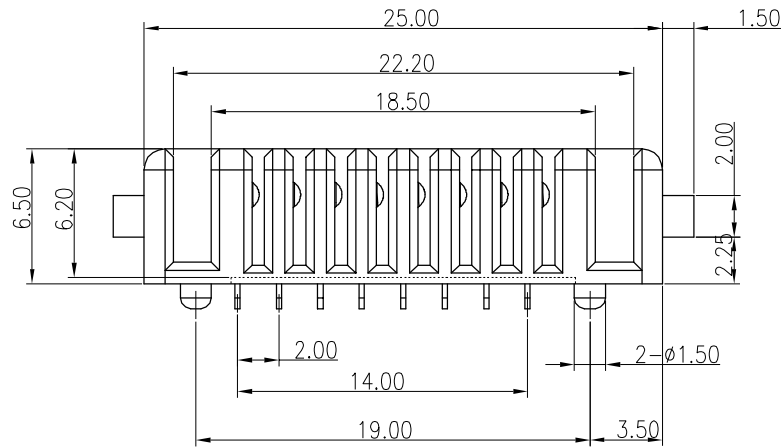
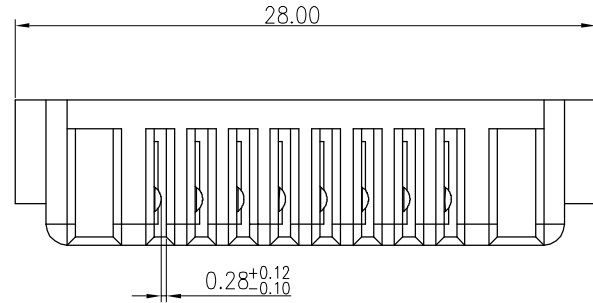
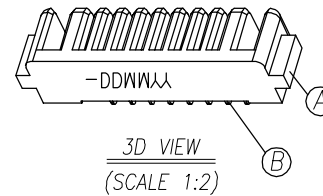

3D VIEW
(SCALE 1:2)

SPECIFICATION:

1. ELECTRICAL PERFORMANCES:

- 1.1 CONTACT RESISTANCE: 20 mΩ MAX.
- 1.2 INSULATION RESISTANCE: 1000 MΩ MIN. BY 500V DC.
- 1.3 DIELECTRIC WITHS TANDING VOLTAGE: 500V AC FOR 1 MINUTE.

2. PERFORMANCE:

- 2.1 VOLTAGE RATING: 30V DC.
- 2.2 CURRENT RATING: 7.0 Amps MAX. PER CONTACT.
- 2.3 OPERATING TEMPERATURE: -40°C~+85°

3. MECHANICAL:

- 3.1 DURABILITY (MATING/UNMATING CYCLES): 5000CYCLES.
- 3.2 MATING FORCE: 0.18~1.5 Kgf.
- UNMTING FORCE: 0.15~1.5 Kgf.

4. HALOGEN FREE PRODUCT IDENTIFICATION MARK ON JACK: ●

5. HALOGEN FREE PRODUCT IDENTIFICATION LABEL ON PACKAGING: ⊙

B	CONTACT	8	COPPER ALLOY	Au 10u" ON CONTACT AREA; Matte Sn 120u" ON SOLDER TAIL, All OVER Ni 50u" MIN.
A	BODY	1	HIGH TEMPERATURE THERMOPLASTIC,UL 94V-0	BLACK
NO	DESCRIPTION	QTY	MATERIAL	PLATING & COLOR
UNLESS OTHERWISE SPECIFED TOLERANCES		Singatron Enterprise Co., Ltd. 信音企業股份有限公司		
DECIMALS: ANGLES:		TITLE		
X :±0.5	X :±2°	DWN	Springwu	BATTERY CONN. FEMALE , DIP
X.X :±0.3	X.X :±1°	CHKD	Sky	PART NO. 2BA3059-008111F
X.XX :±0.2		APVD	Lussen	SCALE:3:1 UNIT: mm
		SIZE: A3 SHEET:1 OF 1 REV: A		
CUSTOMER COPY				