

REV.	EGN NO OR DESCRIPTION	REVISED	DATE
A	PDR NO:A181217-5A	JY	2019.7.31
B	EGN NO:S202002-C07	JY	2020.04.15

SPECIFICATIONS:

- ELECTRICAL CHARACTERISTICS:
 - RATING:DC60V,5A
 - CONTACT RESISTANCE: DISCHARGE PIN:2mΩ MAX.
 - DIELECTRIC WITHSTANDING VOLTAGE: 500V AC FOR ONE MINUTE.
 - INSULATION RESISTANCE: 50M Ω MIN. MEASURED BY 500 VDC.
- MECHANICAL CHARACTERISTICS:
 - INSERTION/WITHDRAWL FORCE : 0.6 kgf Min. (INITIAL)
 - TEMPERATURE RISE CAN'T EXCEED 50°C (ONLY FOR CONNECTOR SIDE)
 - LIFE TEST: 5000 CYCLES MIN.
 - TO CONFORM TO SINGATRON HAZARDOUS SUBSTANCE FREE SPEC.
 - GREEN PRODUCT IDENTIFICATION LABEL ON PACKAGING: **RoHS**
 - MATCH WITH SINGATRON BATTERY MALE CONN.2BW3100 SERIES.
 - WATERPROOF LEVEL: IP56

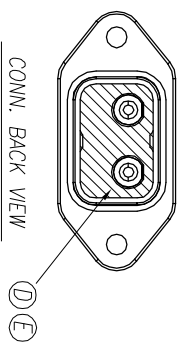
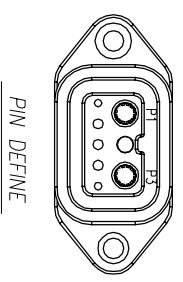
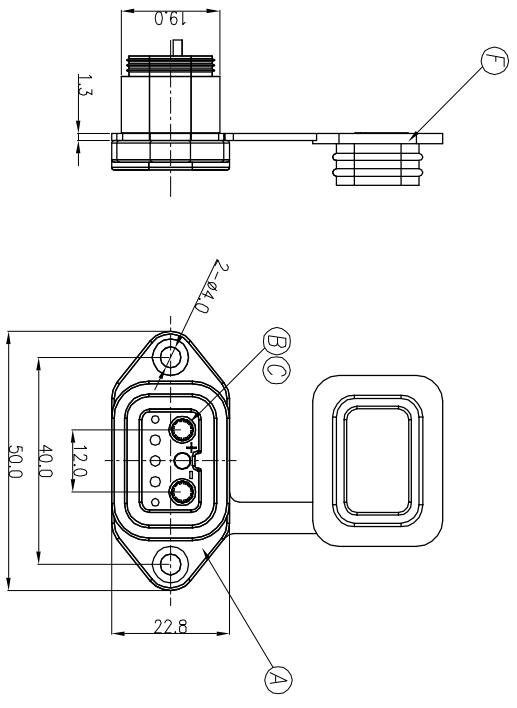
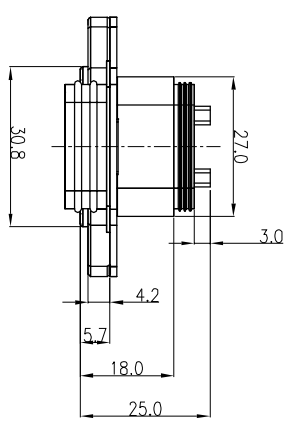

1 2 3 4 5 6 7 8

NO	DESCRIPTION	QTY	MATERIAL	PLATING & COLOR
F	CAP	1	SILICONE	BLACK
E	UV 膠	1	/	WHITE
D	GLUE	1	JAY23	BLACK
C	SPRING	2	COPPER ALLOY	Ag 20u" Min OVER Ni 50u" Min.
B	FEMALE PIN1	2	BRASS	鍍 Ni 50u" Min.
A	HOUSING	1	THERMOPLASTIC	BLACK
UNLESS OTHERWISE SPECIFIED TOLERANCES				
Singatron Enterprise Co., Ltd. 信亨企業股份有限公司				
TITLE: BATTERY FEMALE CONN.				
DWN	JY	PART NO. 2BA3W01-007114H		
CHKD	Cerry	SCALE 2:1	UNIT: mm	
APVD	William	SIZE: A3	SHEET: 1 OF 1	REV: B
CUSTOMER COPY				

A B C D E F

1 2 3 4 5 6 7 8

DECIMALS: ANGLES: X :±0.5 X :±2° X.X :±0.3 X.X :±1' X.XX :±0.2

文件編號: RD-06-043-A