

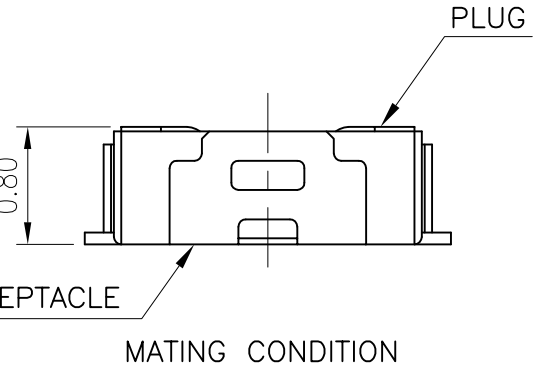

NOTES:

1. MATERIAL:
 - 1.1 HOUSING: THERMOPLASTIC, HIGH TEMP., UL94V-0(LCP); COLOR:BLACK.
 - 1.2 CONTACT: PHOSPHOR BRONZE
 - 1.3 FITTING NAIL:PHOSPHOR BRONZE
2. FINISH:
 - CONTACT:SEE ORDER INFORMATION.
 - UNDERPLATING: 50~100u" NICKEL OVERALL.
3. REFLOW SOLDER CAPABLE TO 260°C PER ACES SPEC.
4. SPEC. PLS. REFER TO PS-51167-xxxxx
5. PACKAGE PLS. REFER TO 51167-XXXCR-XX
6. MATING CONNECTOR P/N:51168
7. PART NUMBER
2BB51167-XXX X X-XXX

CKTS _____ COLOR 001.BLACK
 PACKING 0.TAPE REEL CONTACT PLATING 1.G/F ON CONTACT



PIN	A	B	C	D
10	3.80	3.20	2.50	1.60
12	4.20	3.60	2.90	2.00
14	4.60	4.00	3.30	2.40
24	6.60	6.00	5.30	4.40
30	7.80	7.20	6.50	5.60
40	9.80	9.20	8.50	7.60

一般公差
TOLERANCES
 X ±0.5 XX ±0.15
 X ±0.25 XXX ±0.1
 ANGLES ±2°
 檢驗尺寸標示
 SYMBOLS ⊕ ⊗ INDICATE CLASSIFICATION DIMENSION
 ⊕ MARK IS CRITICAL DIM.
 ⊗ MARK IS MAJOR DIM.

Singatron Enterprise Co., Ltd.			
TITLE	0.4mm 0.8H BOARD TO FPC CONN PLUG		
DWN	15/09/17CARL	PART NO.2BB51167-XXXXX-XXX	
CHKD	ALEX	SCALE 1:1	UNIT: mm
APVD	SEAN	SIZE: A3	SHEET:1 OF 1 REV: E
CUSTOMER COPY			

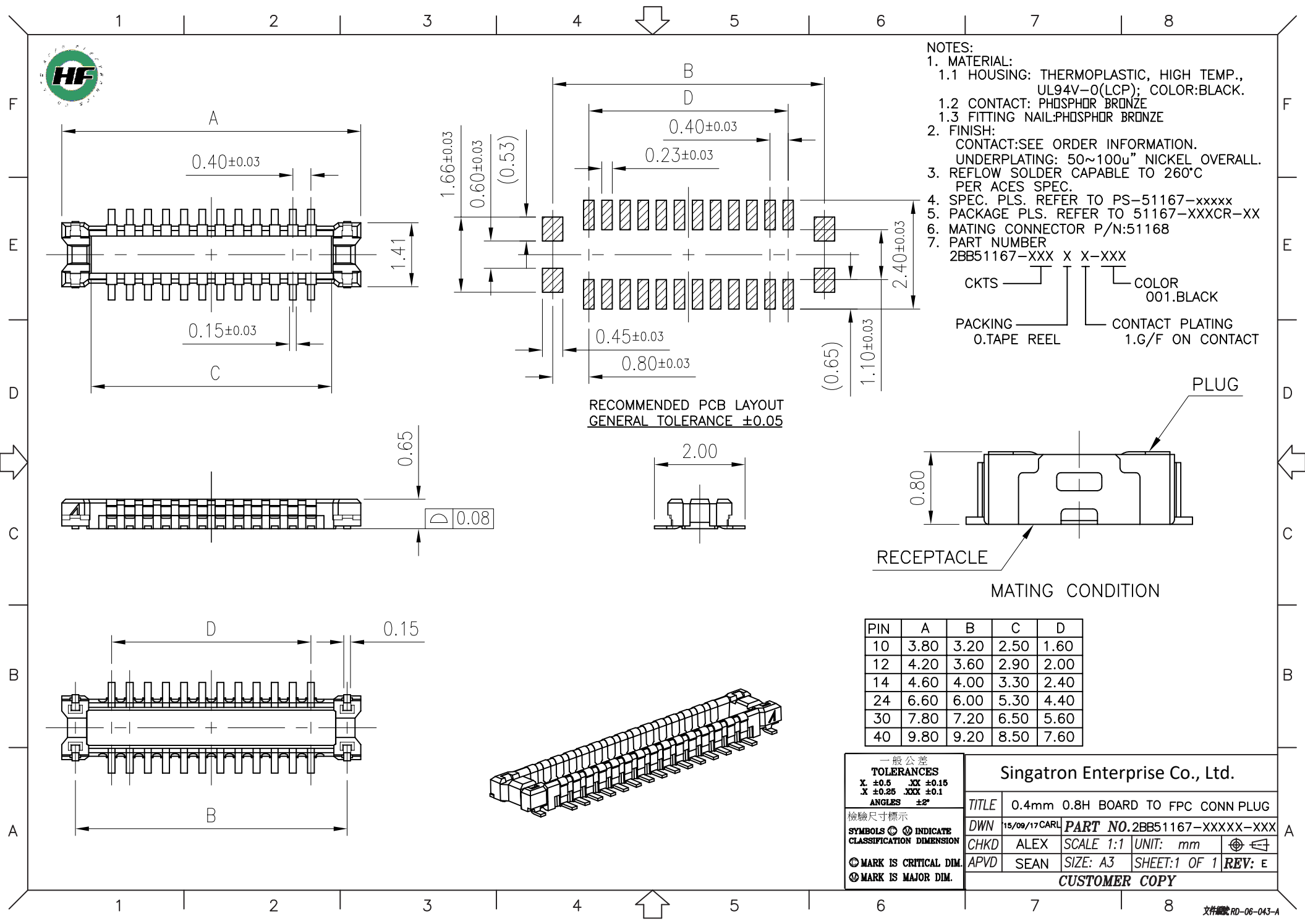

RECOMMENDED PCB LAYOUT
 GENERAL TOLERANCE ±0.05