

REV/ECN NO	OR DESCRIPTION	REVISED	DATE
A	PDR RELEASE	Acheng	2013.10.24

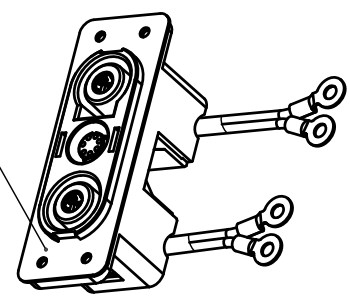

CONNECTOR B WIRE DIAGRAM 7PIN CONNECTOR DETECT PIN

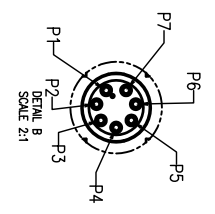
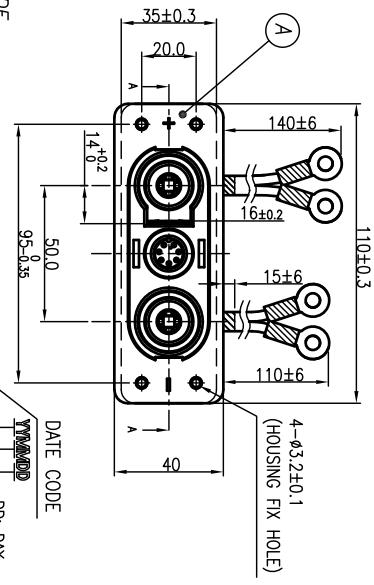
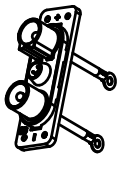
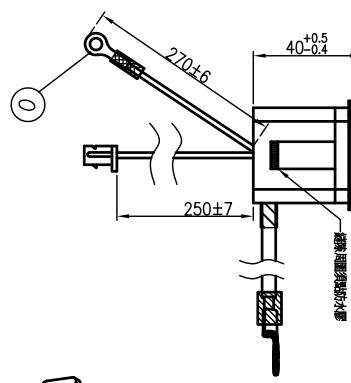
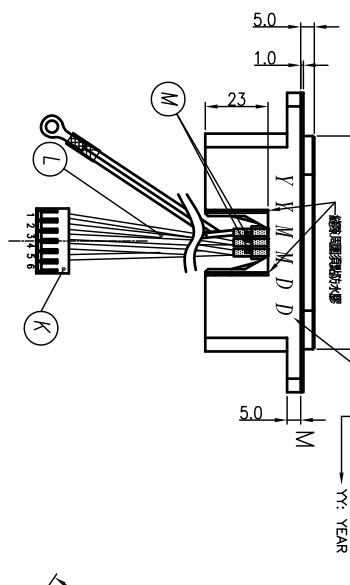
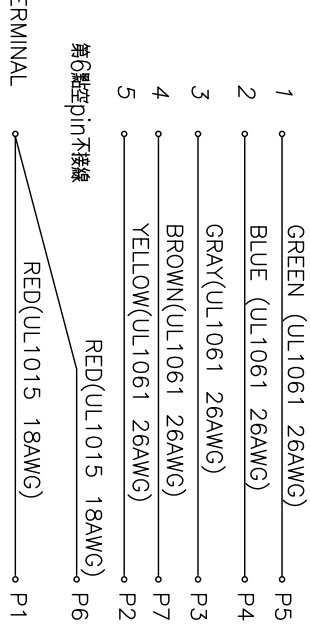

MATING PART P/N 2BA1011 series

SPECIFICATIONS:

- 1-3. CONTACT RESISTANCE: 30mΩ MAX.(SIGNAL PIN+WIRE INITIAL PRE PIN)
- 2-1. INSERTION FORCE : 10KGf Max.(INITIAL)
- 2-2. WITHDRAWAL FORCE : 10KGf Max.(INITIAL)
- 3. LIFE TEST: 5,000 CYCLES MIN.
- 4. OTHER GENERAL SPEC. TO REFER "2BA1010-V07210H SPEC"
- 5. TO CONFORM TO SINGATRON HAZARDOUS SUBSTANCE FREE SPEC.
- 6. GREEN PRODUCT IDENTIFICATION MARK ON JACK
- 7. PRODUCT IDENTIFICATION LABEL ON PACKAGING:
- 8. PACKAGING: BAG

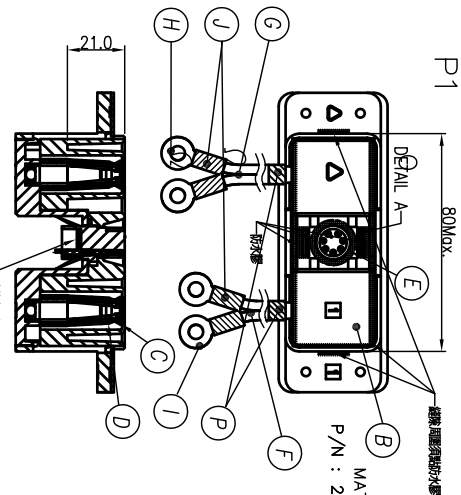

SECTION A-A

P	HEAT SHRINK TUBE	2	φ6 L=30.0	RED/BLACK COLOR
O	R-TERMINAL	1	RWB 1.25-4	TIN PLATING
N	GASKET	1	SILICON	BLACK
M	HEAT SHRINK TUBE	8	φ3 L=15.0	BLACK
L	WIRE	7	SEE WIRE DIAGRAM	SEE WIRE DIAGRAM
K	CONNECTOR B	6	TER.PHOSPHOR BRONZE HSG:NYLON UL94V-0 6P 1.25 PITCH	TIN-PLATED
J	TUBE	4	φ6.5 L=13	WHITE COLOR
I	R-TERMINAL	2	SGE VR5-4	TIN PLATING
H	R-TERMINAL	2	SGE VR5-5	TIN PLATING
G	WIRE	2	UL1015 10AWG	RED COLOR
F	WIRE	2	UL1015 10AWG	BLACK COLOR
E	7 PIN CONNECTOR	1	COPPER ALLOY	GOLD PLATING
D	SPRING	2	SUS304 0.5t	N/A
C	TERMINAL	2	COPPER ALLOY 0.8t	SILVER PLATING
B	COVER	1	HIGH TEMP. THERMOPLASTIC UL 94V-0	BLACK COLOR
A	HOUSING	1	HIGH TEMP. THERMOPLASTIC	BLACK COLOR
NO	DESCRIPTION	QTY	MATERIAL	PLATING & COLOR

Singatron Enterprise Co., Ltd.  
信音企業股份有限公司

PART NO. 2BW1010-V07210H  
BATTERY CONNECTOR+WIRE

DWV	Acheng	PART NO. 2BW1010-V07210H
CHKD	UWE	SCALE 1:2 UNIT: mm
APVD	KARAW	DATE: 2013.10.24 SIZE: A3 SHEET: 1 OF 1 REV: A

CUSTOMER COPY