

REV.	ECN NO OR DESCRIPTION	REVISED	DATE
A	PDR RELEASE	Acheng	2014.07.09
B	ECN NO.T140033	Duke	2015.01.20

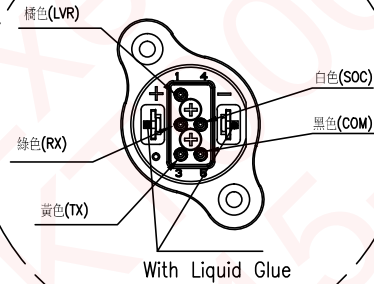

SPECIFICATIONS:

- ELECTRICAL CHARACTERISTICS:
 - 1-1. RATING: 55V DC 20A (PIN+/PIN-)
 - 1-2. CONTACT RESISTANCE: 10mΩ MAX.(PIN+/PIN- W/WIRE INITIAL PRE PIN)
 - 1-3. CONTACT RESISTANCE: 80mΩ MAX.(SIGNAL PIN W/WIRE INITIAL PRE PIN)
- MECHANICAL CHARACTERISTICS:
 - 2-1. INSERTION FORCE : 3.0 ± 2KGF (INITIAL)
 - 2-2. WITHDRAWAL FORCE :3.0 ± 2KGF (INITIAL)
- LIFE TEST: 5,000 CYCLES MIN.
- OTHER GENERAL SPEC. TO REFER "2BW1030-V01210H SPEC".
- TO CONFORM TO SINGATRON HAZARDOUS SUBSTANCE FREE SPEC.
- GREEN PRODUCT IDENTIFICATION MARK ON JACK:
- PRODUCT IDENTIFICATION LABEL ON PACKAGING:
- PACKAGING: BAG

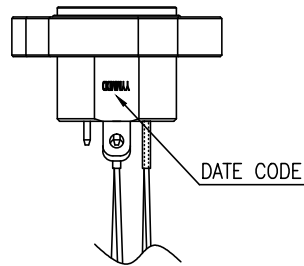
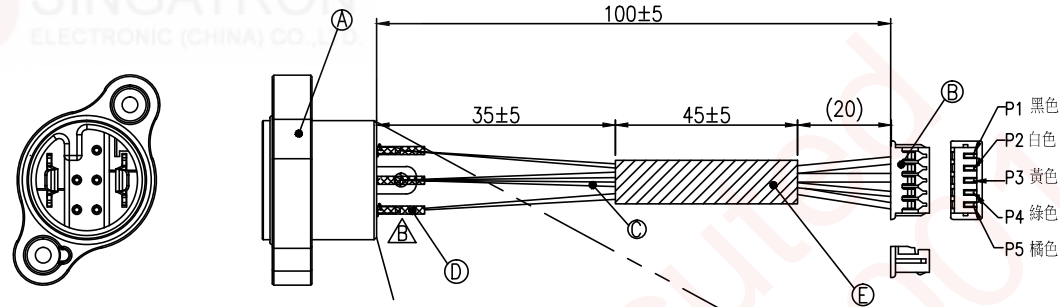
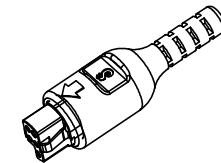
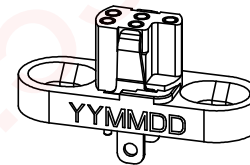

MATING PART
P/N:2BA1029 SERIES

MATING PART
P/N:2CT1001 SERIES

BATTERY CONNECTOR	WIRE DIAGRAM	CONNECTOR(A)
SIGNAL 5	黑色 (UL1061 28AWG)	P1
SIGNAL 4	白色 (UL1061 28AWG)	P2
SIGNAL 3	黄色 (UL1061 28AWG)	P3
SIGNAL 2	綠色 (UL1061 28AWG)	P4
SIGNAL 1	橘色 (UL1061 28AWG)	P5

E	TERHEAT SHRINK TUBE	1	ø3.5*L45	BLACK
D	TERHEAT SHRINK TUBE	4	ø2.4*L15含膠	BLACK
C	WIRE	5	SEE WIRE DIAGRAM	N/A
B	CONNECTOR A	1	HOUSING(4HRWST-1250105)	WHITE
		5	TERMINAL(4TRWST-1250101)	TIN PLATING
A	BATTERY CONNECTOR	1	2BA1030-V00210F	N/A
NO	DESCRIPTION	QTY	MATERIAL	PLATING & COLOR

UNLESS OTHERWISE SPECIFIED TOLERANCES

Singatron Enterprise Co., Ltd.
信音企業股份有限公司

DECIMALS:	ANGLES:	TITLE	BATTERY CONNECTOR+WIRE	
X :±0.5	X :±2°	DWN Duke	PART NO. 2BW1030-V01210H	
X.X :±0.3	X.X :±1°	CHKD	SCALE 1:1	UNIT: mm
X.XX :±0.2		APVD	SIZE: A3	SHEET:1 OF 1
CUSTOMER COPY				

專務經理	高鎮專員
AE Team (HKT)	產品技術部 (HKT)
呂建威	范義秀琴
2015/01/21 14:43:41	2015/01/21 14:45:29