

REV.	ECN NO OR DESCRIPTION	REVISED	DATE
A	PDR NO: S170309-4A	CERRY	2017.12.07
B	ECN NO: A180608-C	JTT	2018.06.13

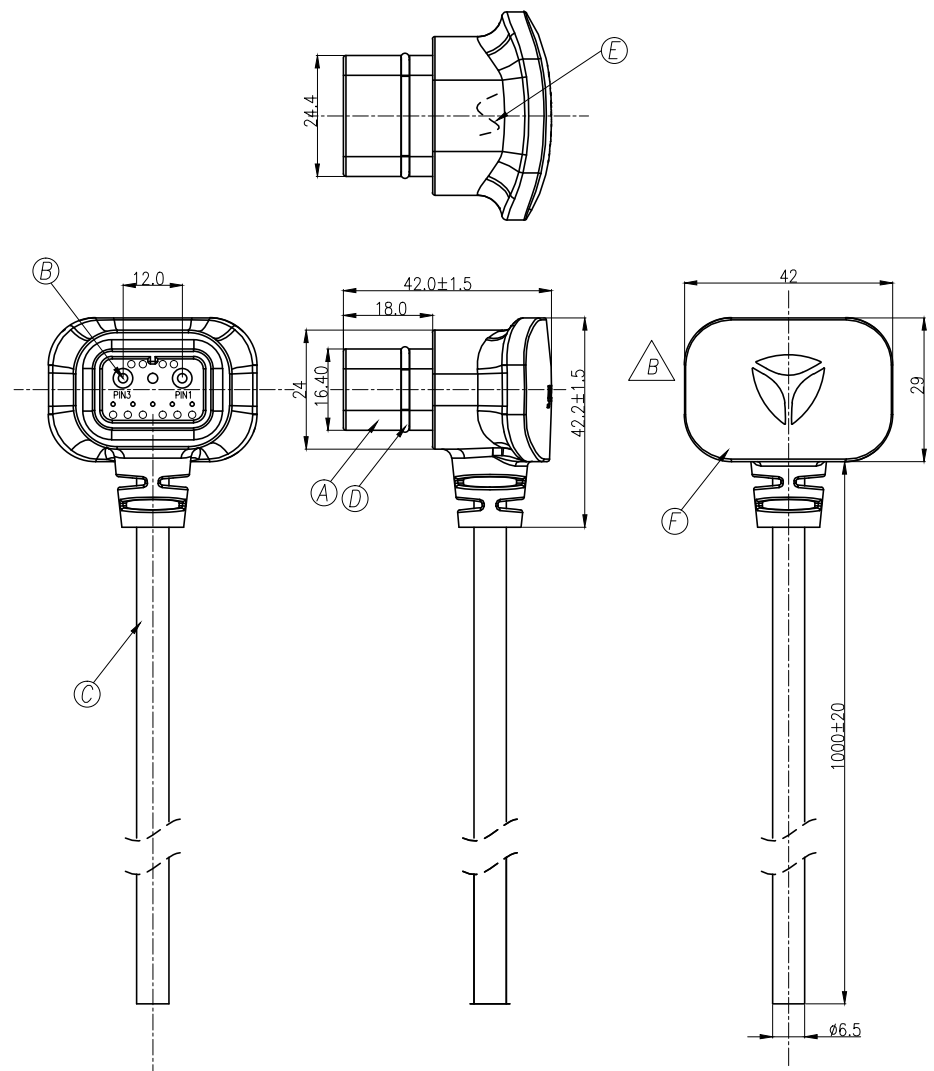

SPECIFICATIONS:

- ELECTRICAL CHARACTERISTICS:**
 - 1-1. RATING:DC48V,30A
 - 1-2. CONTACT RESISTANCE: 2 Ω MAX.(WITH CABLE)
 - 1-3. DIELECTRIC WITHSTANDING VOLTAGE: 500V AC FOR ONE MINUTE.
 - 1-4. INSULATION RESISTANCE: 50M Ω MIN. MEASURED BY 500 VDC
- MECHANICAL CHARACTERISTICS:**
 - 2-1. INSERTION/WITHDRAWL FORCE : 0.6 kgf Min. (INITIAL)
- TEMPERATURE RISE CAN'T EXCEE 60°C (ONLY FOR CONNECTOR SIDE)
- LIFE TEST: 5000 CYCLES MIN.
- TO CONFORM TO SINGATRON HAZARDOUS SUBSTANCE FREE SPEC.
- GREEN PRODUCT IDENTIFICATION LABEL ON PACKAGING: **G.P. PASS**
- MATCH WITH SINGATRON BATTERY FEMALE CONN.2BA3W01-000114H

F	OVER MOLD	1	PLASTIC	BLACK
E	INNER MOLD	1	PLASTIC	NATURE
D	O-RING	1	SILICONE	GRAY
C	CABLE	1	2*1mm ² PVC	BLACK
B	CHARGE PIN	2	BRASS	Ag 60u" Min OVER 50u" Ni.
A	HOUSING	1	THERMOPLASTIC	BLACK
NO	DESCRIPTION	QTY	MATERIAL	PLATING & COLOR

UNLESS OTHERWISE SPECIFIED TOLERANCES		Singatron Enterprise Co., Ltd. 信音企業股份有限公司		
DECIMALS:	ANGLES:	TITLE	BATTERY CHARGE CONN. WITH CABLE	
X :±0.5	X :±2°	DWN	JTT	PART NO. 2BW3100-000111H
X.X :±0.3	X.X :±1°	CHKD	CERRY	SCALE 2:1 UNIT: mm
X.XX :±0.2		APVD	WILLIAM	SIZE: A3 SHEET:1 OF 1 REV: B
CUSTOMER COPY				

NO.	WIRE COLOR	WIRE SPEC.
Pin1	RED	1mm ²
Pin3	BLACK	1mm ²