

REV.	ECN NO OR DESCRIPTION	REVISED	DATE
A	PDR NO:A180704-1A	JTT	2019.07.02

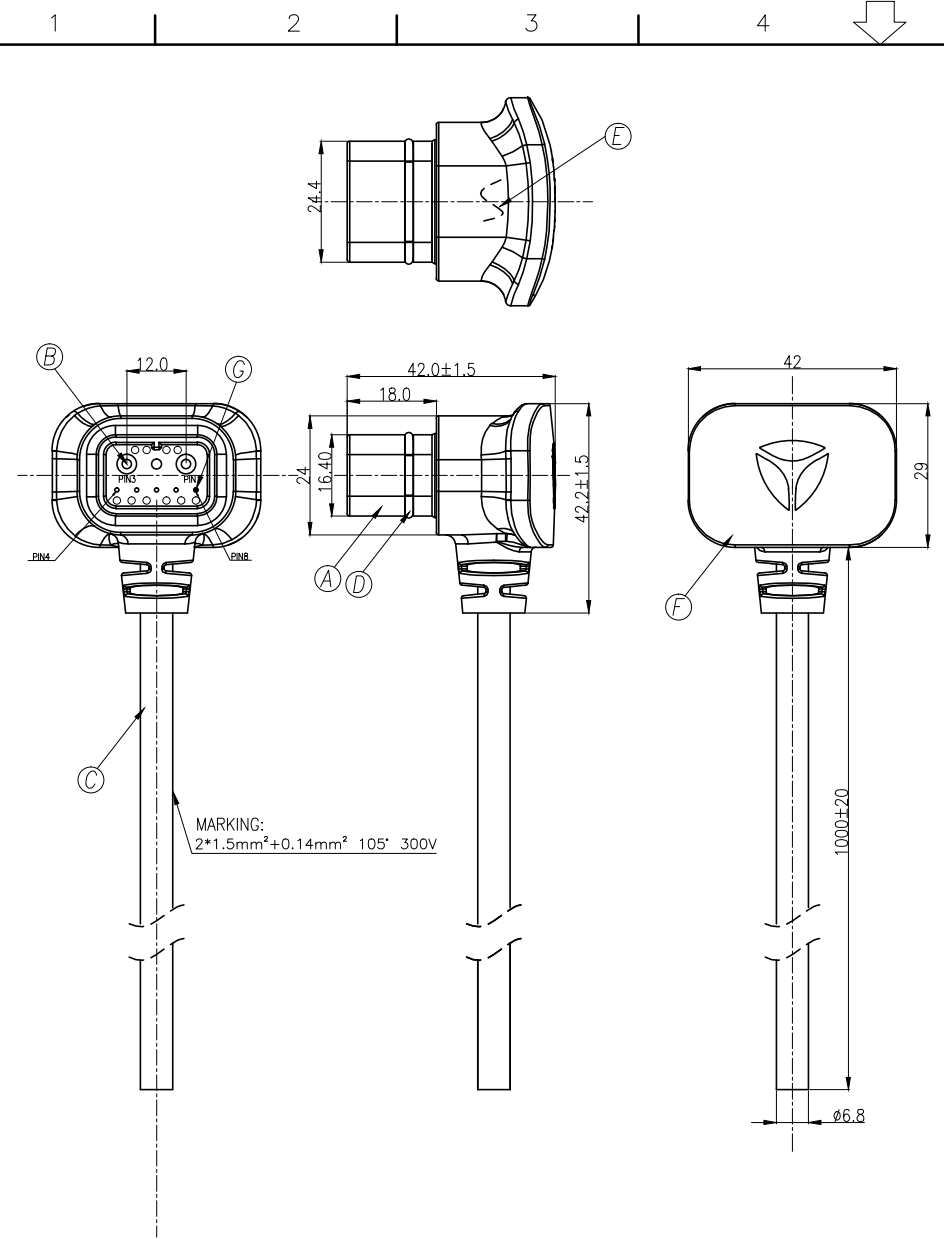

SPECIFICATIONS:

- ELECTRICAL CHARACTERISTICS:
  - RATING:DC48V,10A
  - CONTACT RESISTANCE: 2 Ω MAX.(WITH CABLE)
  - DIELECTRIC WITHSTANDING VOLTAGE: 500V AC FOR ONE MINUTE.
  - INSULATION RESISTANCE: 50M Ω MIN. MEASURED BY 500 VDC
- MECHANICAL CHARACTERISTICS:
  - INSERTION/WITHDRAWL FORCE : 0.6 kgf Min. (INITIAL)
- TEMPERATURE RISE CAN'T EXCEED 50°C (ONLY FOR CONNECTOR SIDE)
- LIFE TEST: 5000 CYCLES MIN.
- TO CONFORM TO SINGATRON HAZARDOUS SUBSTANCE FREE SPEC.
- GREEN PRODUCT IDENTIFICATION LABEL ON PACKAGING: **G.P. PASS**
- MATCH WITH SINGATRON BATTERY FEMALE CONN.2BA3W01-000114H

G	PIN2	1	BRASS	Ag 20u" Min Over Nickel Plating
F	OVER MOLD	1	PLASTIC	BLACK
E	INNER MOLD	1	PLASTIC	NATURE
D	O-RING	1	SILICONE	GRAY
C	CABLE	1	2*1.5mm <sup>2</sup> +0.14mm <sup>2</sup> PVC	BLACK
B	CHARGE PIN1	2	BRASS	Ni 60u" Min.
A	HOUSING	1	THERMOPLASTIC	BLACK
NO	DESCRIPTION	QTY	MATERIAL	PLATING & COLOR

UNLESS OTHERWISE SPECIFIED TOLERANCES		Singatron Enterprise Co., Ltd. 信音企業股份有限公司			
DECIMALS:	ANGLES:	TITLE	BATTERY CHARGE CONN. WITH CABLE		
X :±0.5	X :±2°	DWN	JTT	<b>PART NO. 2BW3100-004111H</b>	
X.X :±0.3	X.X :±1°	CHKD	Cerry	SCALE 2:1	UNIT: mm
X.XX :±0.2		APVD	William	SIZE: A3	SHEET:1 OF 1
<b>REV: A</b>					
<b>CUSTOMER COPY</b>					

NO.	WIRE COLOR	WIRE SPEC.
Pin1	RED	1.5mm <sup>2</sup>
Pin3	BLACK	1.5mm <sup>2</sup>
Pin8	WHITE	0.14mm <sup>2</sup>