

REV.	ECN NO OR DESCRIPTION	REVISED	DATE
A	PDR NO.:181101-5B	Vincent	2019.07.11
B	ECN NO.:A190807-C	Vincent	2019.12.19

SPECIFICATIONS:

- ELECTRICAL CHARACTERISTICS:
 - RATING:DC48V,10A
 - CONTACT RESISTANCE: 2 Ω MAX.(WITH CABLE)
 - DIELECTRIC WITHSTANDING VOLTAGE: 500V AC FOR ONE MINUTE.
 - INSULATION RESISTANCE: 50M Ω MIN. MEASURED BY 500 VDC
- MECHANICAL CHARACTERISTICS:
 - INSERTION/WITHDRAWAL FORCE : 0.6 kgf Min. (INITIAL)
- TEMPERATURE RISE CAN'T EXCEED 50°C (ONLY FOR CONNECTOR SIDE)
- LIFE TEST: 5000 CYCLES MIN.
- TO CONFORM TO SINGATRON HAZARDOUS SUBSTANCE FREE SPEC.
- GREEN PRODUCT IDENTIFICATION LABEL ON PACKAGING: **G.P. PASS**
- MATCH WITH SINGATRON BATTERY FEMALE CONN.

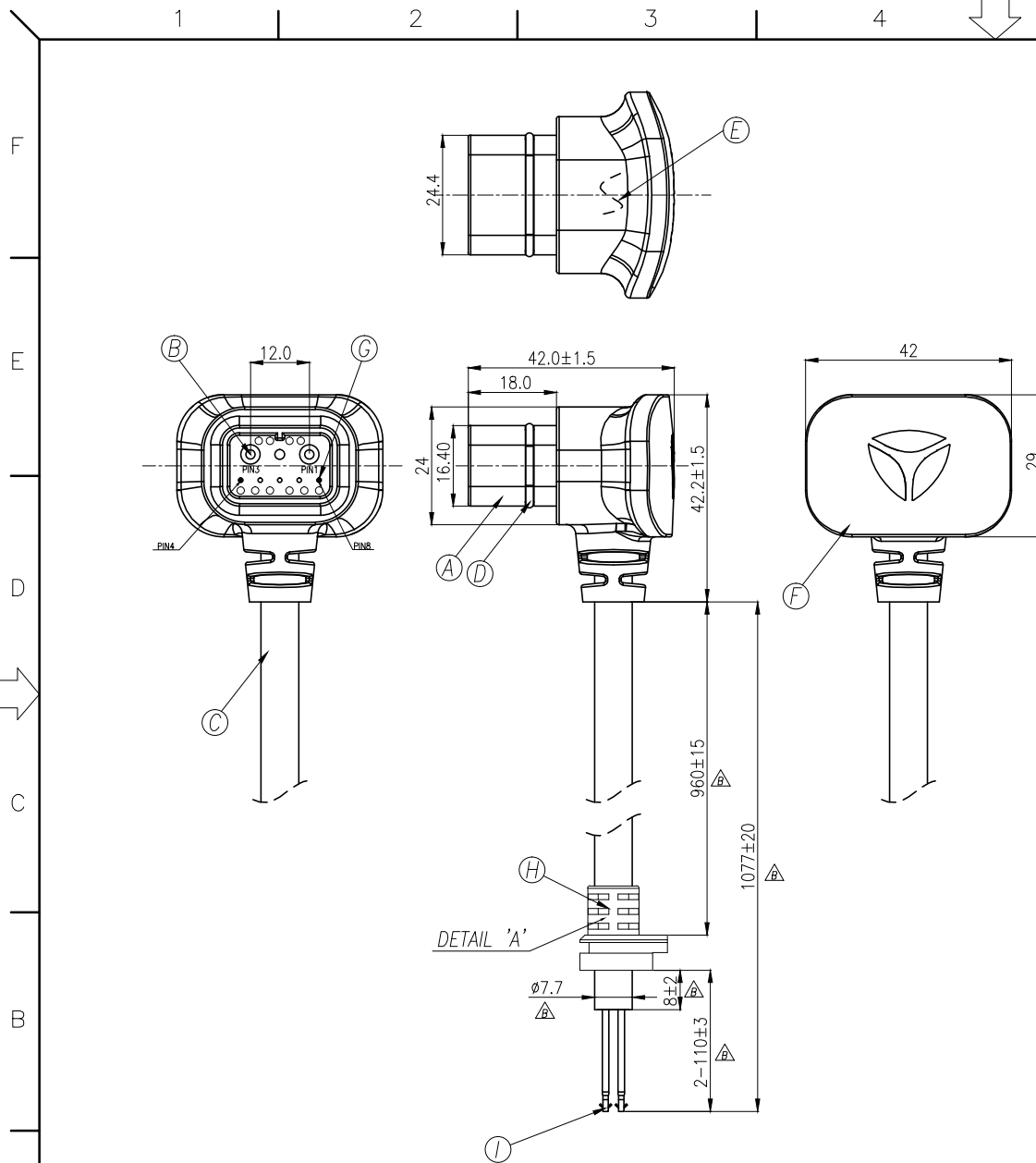
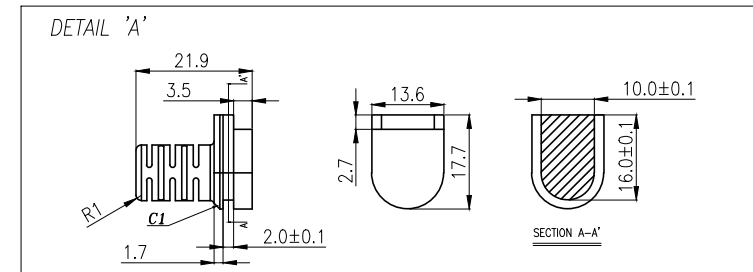

NO.	WIRE COLOR		
Pin1	RED	Short	Short
Pin3	BLACK		
Pin4			
Pin8			

NO	DESCRIPTION	QTY	MATERIAL	PLATING & COLOR
I	TERMINAL	2	JWT B1811T2P-2e	TIN PLATED
H	SR	1	PLASTIC	BLACK
G	PIN2	2	BRASS	Ag 20u" Min Over Nickel Plating
F	OVER MOLD	1	PLASTIC	BLACK
E	INNER MOLD	1	PLASTIC	NATURE
D	O-RING	1	SILICONE	GRAY
C	CABLE	1	IEC53(RV)2*1.5mm ² PVC	BLACK
B	CHARGE PIN1	2	BRASS	Ni 60u" Min.
A	HOUSING	1	THERMOPLASTIC	BLACK

UNLESS OTHERWISE SPECIFIED TOLERANCES		Singatron Enterprise Co., Ltd. 信音企業股份有限公司			
DECIMALS:	ANGLES:	TITLE	BATTERY CHARGE CONN. WITH CABLE		
X :±0.5	X :±2°	DWN Vincent	PART NO. 2BW3100-006111H		
X.X :±0.3	X.X :±1°	CHKD Cerry	SCALE 2:1	UNIT: mm	
X.XX :±0.2		APVD William	SIZE: A3	SHEET: 1 OF 1	REV: B
CUSTOMER COPY					