

REV.	ECN NO OR DESCRIPTION	REVISED	DATE
A	PDR NO.:A190304-6A	JTT	2019.06.13

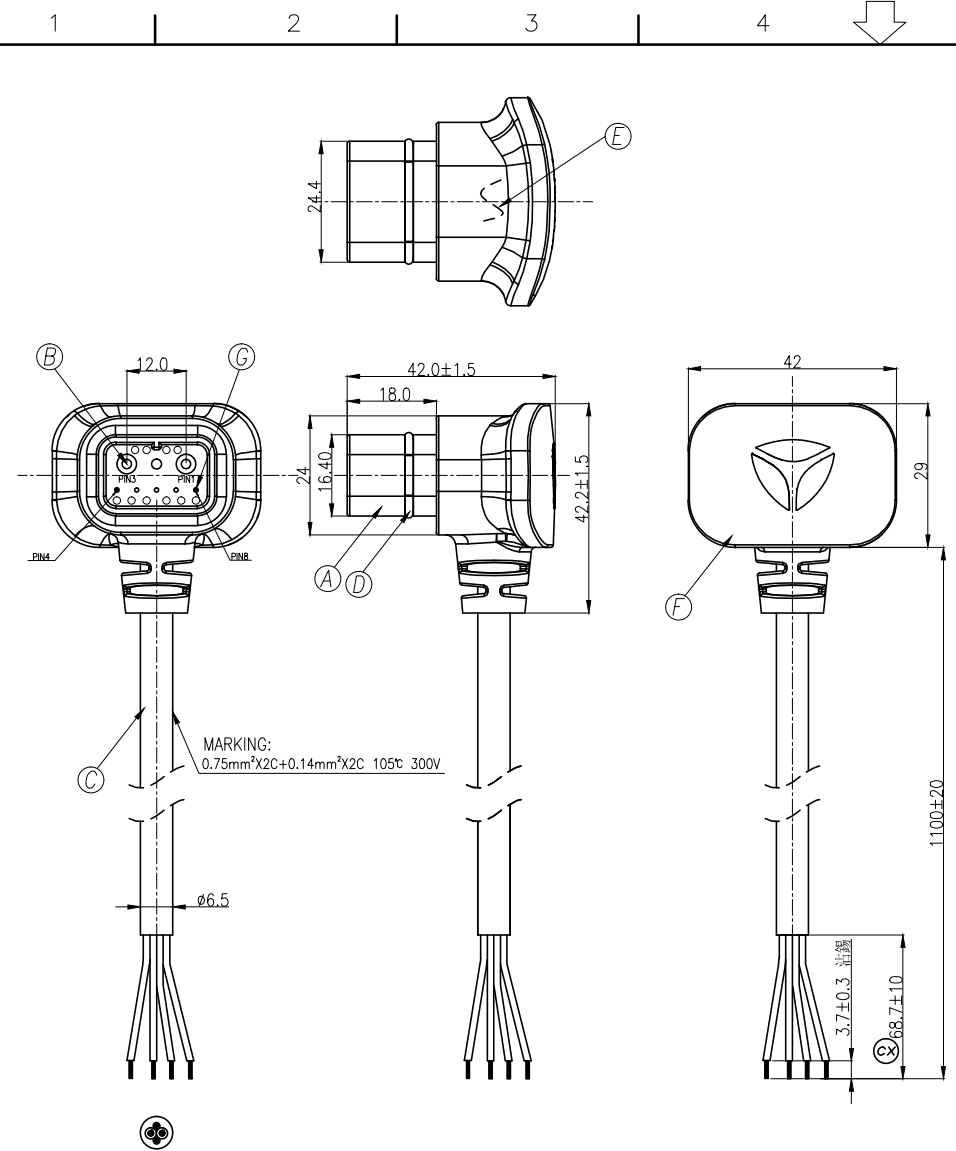

SPECIFICATIONS:

- ELECTRICAL CHARACTERISTICS:
  - RATING:DC48V,3A
  - CONTACT RESISTANCE: 2 Ω MAX.(WITH CABLE)
  - DIELECTRIC WITHSTANDING VOLTAGE: 500V AC FOR ONE MINUTE.
  - INSULATION RESISTANCE: 50M Ω MIN. MEASURED BY 500 VDC
- MECHANICAL CHARACTERISTICS:
  - INSERTION/WITHDRAWAL FORCE : 0.6 kgf Min. (INITIAL)
- TEMPERATURE RISE CAN'T EXCEE 60°C (ONLY FOR CONNECTOR SIDE)
- LIFE TEST: 5000 CYCLES MIN.
- TO CONFORM TO SINGATRON HAZARDOUS SUBSTANCE FREE SPEC.
- GREEN PRODUCT IDENTIFICATION LABEL ON PACKAGING: **G.P. PASS**
- MATCH WITH SINGATRON BATTERY FEMALE CONN.

G	PIN2	2	BRASS	Ag 20u" Min OVER 50u" Ni.
F	OVER MOLD	1	PLASTIC	BLACK
E	INNER MOLD	1	PLASTIC	NATURE
D	O-RING	1	SILICONE	GRAY
C	CABLE	1	2*0.75mm²+2*0.14mm²	PVC BLACK
B	CHARGE PIN1	2	BRASS	Ni 60u" Min.
A	HOUSING	1	THERMOPLASTIC	BLACK
NO	DESCRIPTION	QTY	MATERIAL	PLATING & COLOR

UNLESS OTHERWISE SPECIFIED TOLERANCES		Singatron Enterprise Co., Ltd. 信音企業股份有限公司		
DECIMALS:	ANGLES:	TITLE	BATTERY CHARGE CONN. WITH CABLE	
X :±0.5	X :±2°	DWN	JTT	<b>PART NO. 2BW3100-007111H</b>
X.X :±0.3	X.X :±1°	CHKD	Cerry	SCALE 2:1 UNIT: mm
X.XX :±0.2		APVD	William	SIZE: A3 SHEET:1 OF 1 <b>REV: A</b>
<b>CUSTOMER COPY</b>				

NO.	WIRE COLOR	WIRE SPEC.
Pin1	RED	0.75mm²
Pin3	BLACK	0.75mm²
Pin4	BLACK	0.14mm²
Pin8	WHITE	0.14mm²