

REV.	ECN NO OR DESCRIPTION	REVISED	DATE
A	PDR NO:A171226-2A	JTT	2019.02.16

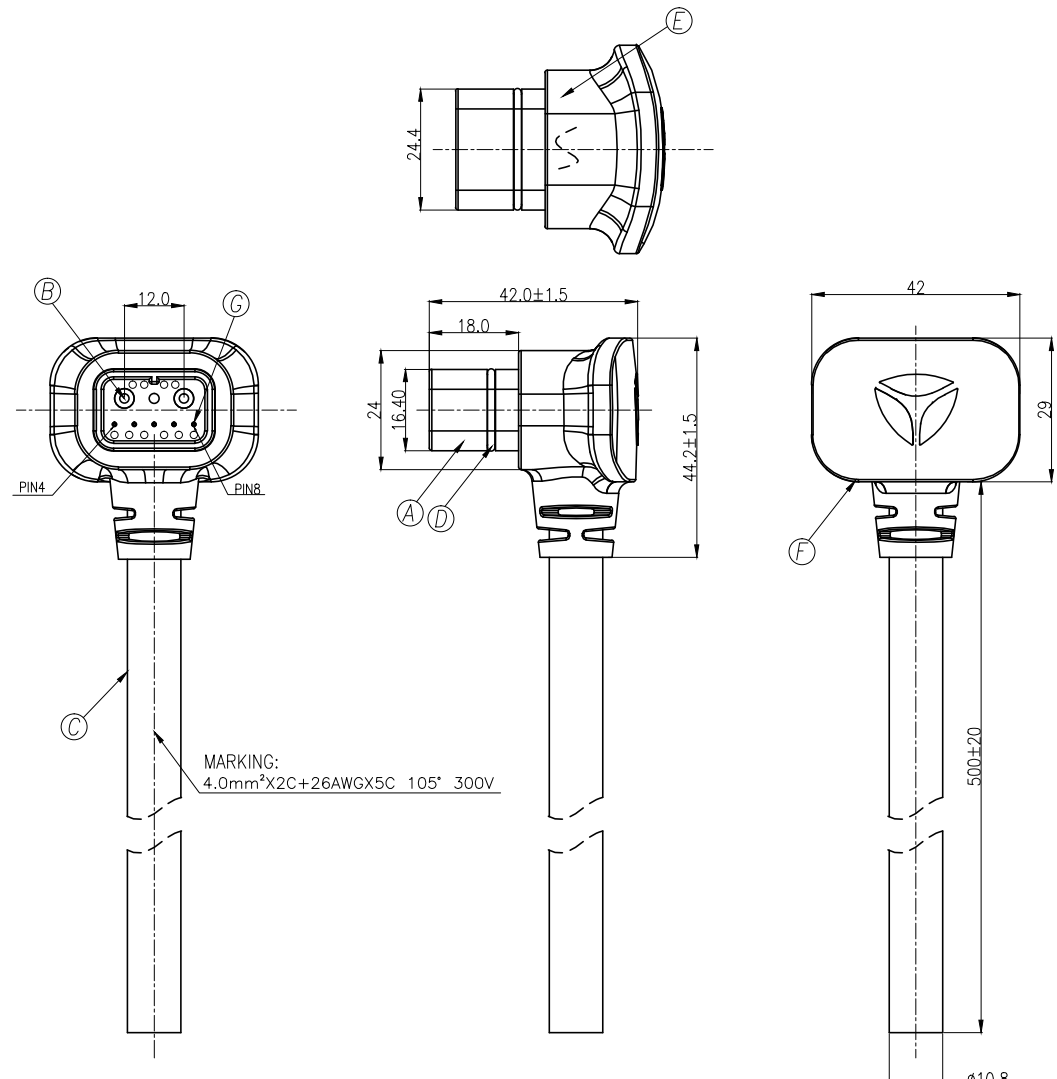

SPECIFICATIONS:

- ELECTRICAL CHARACTERISTICS:
 - RATING:DC60V,32A PEAK45A.
 - CONTACT RESISTANCE: 2 Ω MAX.(WITH CABLE)
 - DIELECTRIC WITHSTANDING VOLTAGE: 500V AC FOR ONE MINUTE.
 - INSULATION RESISTANCE: 50M Ω MIN. MEASURED BY 500 VDC
- MECHANICAL CHARACTERISTICS:
 - INSERTION/WITHDRAWL FORCE : 0.6 kgf Min. (INITIAL)
- TEMPERATURE RISE CAN'T EXCEE 50°C (ONLY FOR CONNECTOR SIDE)
- LIFE TEST: 5000 CYCLES MIN.
- TO CONFORM TO SINGATRON HAZARDOUS SUBSTANCE FREE SPEC.
- GREEN PRODUCT IDENTIFICATION LABEL ON PACKAGING: **G.P. PASS**
- MATCH WITH SINGATRON BATTERY FEMALE CONN.2BA3W01-002114H

G	PIN2	5	BRASS	Ag 20u" Min OVER 50u" Ni.
F	OVER MOLD	1	PLASTIC	BLACK
E	INNER MOLD	1	PLASTIC	NATURE
D	O-RING	1	SILICONE	GRAY
C	CABLE	1	4.0mm²X2C+26AWGX5C XLPVC	BLACK
B	DISCHARGE PIN1	2	BRASS	Ag 60u" Min OVER 50u" Ni.
A	HOUSING	1	THERMOPLASTIC	BLACK
NO	DESCRIPTION	QTY	MATERIAL	PLATING & COLOR

UNLESS OTHERWISE SPECIFIED TOLERANCES		Singatron Enterprise Co., Ltd. 信音企業股份有限公司	
DECIMALS:	ANGLES:	TITLE	BATTERY DISCHARGE CONN. WITH CABLE
X :±0.5	X :±2°	DWN	JTT
X.X :±0.3	X.X :±1°	CHKD	Cerry
X.XX :±0.2		APVD	William
		SCALE	2:1
		UNIT	mm
		SIZE	A3
		SHEET	1 OF 1
		REV	A
CUSTOMER COPY			

NO.	WIRE COLOR	WIRE SPEC.
Pin1	RED	4mm²
Pin3	BLACK	4mm²
Pin4	WHITE	26AWG
Pin5	GREEN	26AWG
Pin6	BLUE	26AWG
Pin7	YELLOW	26AWG
Pin8	BLACK	26AWG