

REV.	ECN NO.	OR DESCRIPTION	REVISED	DATE
A	PDR NO:	A220517-1A	LEI	2023.02.15

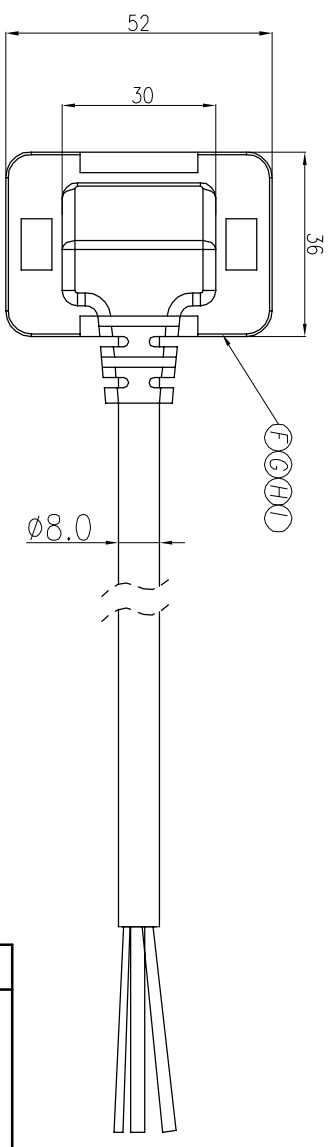
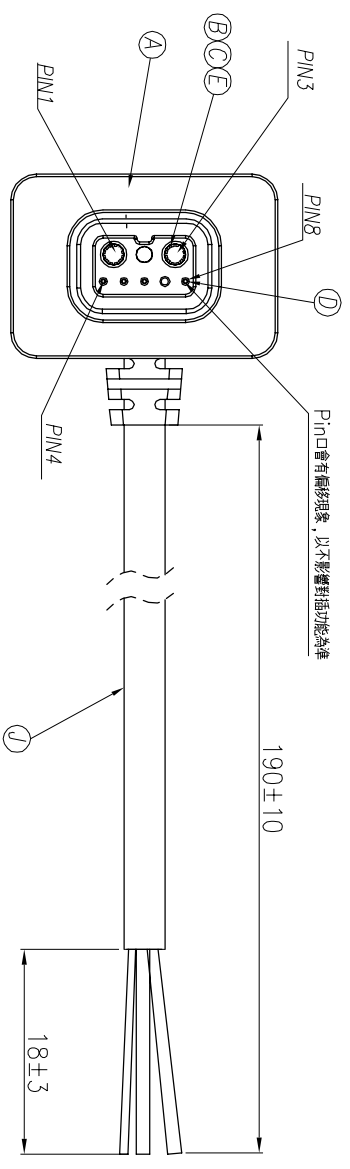

Pin	WIRE COLOR	WIRE SPEC.
Conn1	RED	2.0mm ²
Pin1	RED	2.0mm ²
Pin2	BLACK	2.0mm ²
Pin3	BLUE	22AWG
Pin4	BROWN	22AWG
Pin5	BLACK	22AWG
Pin6	BLACK	22AWG
Pin7	WHITE	22AWG
Pin8	WHITE	22AWG

SPECIFICATIONS:

- ELECTRICAL CHARACTERISTICS:**
 - 1-1. RATING:DC48V,10A
 - 1-2. CONTACT RESISTANCE: $2m\Omega$ Max.
 - 1-3. DIELECTRIC WITHSTANDING VOLTAGE: 500V AC FOR ONE MINUTE.
 - 1-4. INSULATION RESISTANCE: 50M Ω Min. MEASURED BY 500 VDC
- MECHANICAL CHARACTERISTICS:**
 - 2-1. INSERTION/WITHDRAWL FORCE : 0.6 kgf Min. (INITIAL)
- TEMPERATURE RISE CAN'T EXCEED 50°C (ONLY FOR CONNECTOR SIDE)
- LIFE TEST: 5000 CYCLES Min.
- TO CONFORM TO SINGATRON HAZARDOUS SUBSTANCE FREE SPEC.
- GREEN PRODUCT IDENTIFICATION LABEL ON PACKAGING:
- MATCH WITH SINGATRON BATTERY MALE CONN.2BW3100 SERIES.
- WATERPROOF LEVEL: IP56

NO	DESCRIPTION	QTY	MATERIAL	PLATING & COLOR
J	CABLE	1	2.0mm ² *2C+22AWG*4C	BLACK
I	HEAT SHRINK TUBE	5	$\phi 2.4$	BLACK
H	INNER MOLD	1	PLASTIC	BLACK
G	OVER MOLD	1	PLASTIC	BLACK
F	GLUE	1	EPOXY RESIN	BLACK
E	FEMALE PIN CAP	2	C3604	Ni 50u"Min.
D	FEMALE PIN2	4	BRASS	AU PLATING
C	SPRING	2	COPPER ALLOY	AU PLATING
B	FEMALE PIN1	2	BRASS	Ni PLATING
A	HOUSING	1	THERMOPLASTIC UL94-V0	BLACK
NO	DESCRIPTION	QTY	MATERIAL	PLATING & COLOR
UNLESS OTHERWISE SPECIFIED TOLERANCES				
Suzhou Singatron Auto Electronics CO.,LTD. 蘇州新特龍汽車電子有限公司				
TITLE BATTERY CHARGE CONN. WITH CABLE				
DWN	LEI	PART NO.	2BW3W01-W06D03H	
CHKD	Jun	SCALE	2:1	UNIT: mm
APVD	Steve	SIZE: A3	SHEET: 1 OF 1	REV: A

CUSTOMER COPY