

| REV/ECN NO OR DESCRIPTION | REVISED | DATE       |
|---------------------------|---------|------------|
| A PDR RELEASE             | IVY-C   | 2011.08.22 |
| B ECN NO. L120147         | IVY-C   | 2012.11.12 |

**SPECIFICATIONS:**

1. OTHER GENERAL SPEC. TO REFER "2CA1506 SERIES SPEC".
2. TO CONFORM TO SINGATRON HAZARDOUS SUBSTANCE FREE SPEC.
3. GREEN PRODUCT IDENTIFICATION LABEL ON PACKAGING: **[G.P. PASS]**
4. PACKAGE : SEE " 2CA1525 SERIES " PACKAGE.
5. SOLDER HEAT RESISTANCE: WAVE SOLDERING 260°C 10SECS.

**PART NO.**

**2CA1525-000111H**

- SUFFIX: HALOGEN
- PACKAGE
- 1: TRAY
- HOUSING COLOR
- 1: BLACK
- CONTACT PLATING
- 1: GOLD FLASH ON CONTACT AREA,
- TIN PLATING ON SOLDER AREA

| PIN TYPE  | DIM L±0.10mm | PIN NUMBER            |
|-----------|--------------|-----------------------|
| DETECT    | 3.50         | 36, 67                |
| GENERAL   | 4.25         | ALL OTHER PINS        |
| POWER/GND | 5.00         | 1, 17, 34, 35, 51, 68 |

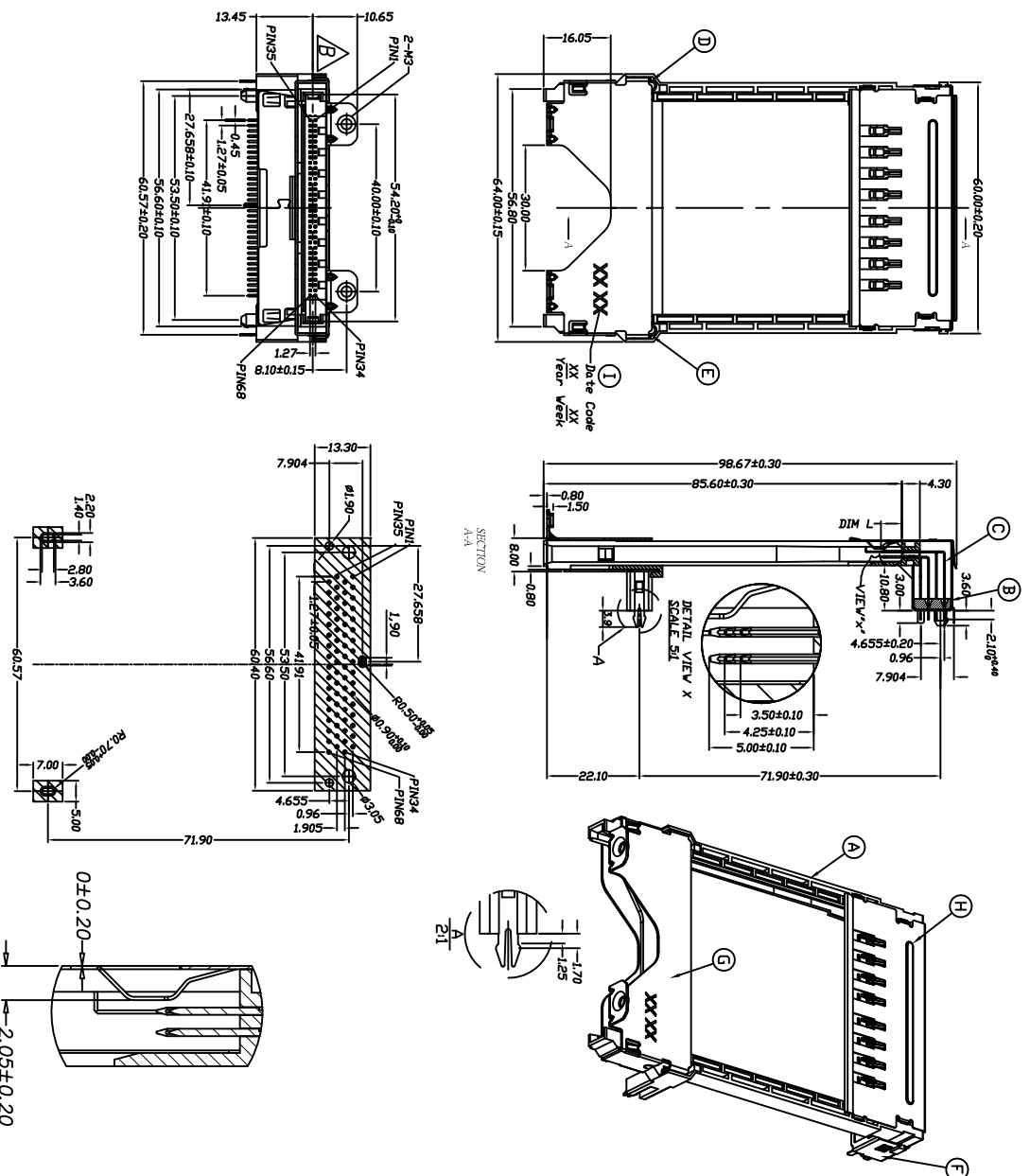

RECOMMENDED PCB LAYOUT (TOP VIEW)  
 RECOMMENDED PCB THK.=1.60±0.10  
 TOLERANCE: ±0.05

GND FINGER VIEW

| NO                                    | DESCRIPTION    | QTY | MATERIAL           | PLATING & COLOR  |
|---------------------------------------|----------------|-----|--------------------|------------------|
| UNLESS OTHERWISE SPECIFIED TOLERANCES |                |     |                    |                  |
| H                                     | CARD BUS SHELL | 1   | STAINLESS STEEL    | N/A              |
| G                                     | TOP SHELL      | 1   | SPCC               | NICKEL           |
| F                                     | EMI SHELL      | 1   | STAINLESS STEEL    | TIN              |
| E                                     | RIGHT HOOK PIN | 1   | COPPER ALLOY       | GOLD FLASH / TIN |
| D                                     | LEFT HOOK PIN  | 1   | COPPER ALLOY       | GOLD FLASH / TIN |
| C                                     | CONTACT        | 68  | COPPER ALLOY       | GOLD FLASH / TIN |
| B                                     | LOCATOR        | 1   | PBT+GF30%(UL94V-0) | BLACK            |
| A                                     | BASE           | 1   | PBT+GF30%(UL94V-0) | BLACK            |
| NO                                    | DESCRIPTION    | QTY | MATERIAL           | PLATING & COLOR  |

Singatron Enterprise Co., Ltd.  
 信音企業股份有限公司

|           |  |
|-----------|--|
| TITLE     | 68P PCMCIA CARDBUS,108H, TOP SHELL GROUNDING |
| DWN       | HW-C-2012.11.12                              |
| CHKD      | HW-C-2012.11.12                              |
| APVD      | HW-C-2012.11.12                              |
| PART NO.  | 2CA1525-000111H                              |
| SCALE:N/A |  |
| UNIT:     | mm   |
| SIZE:     | A3   |
| SHEET:    | 1 OF 1                                       |
| REV:      | B  |

CUSTOMER COPY