

REV.	ECN NO OR DESCRIPTION	REVISED	DATE
A	PDR NO.:T100108-4A	Joe-Iloo	2010.01.26
B	ECN NO.:S121109	YF	2014.03.27

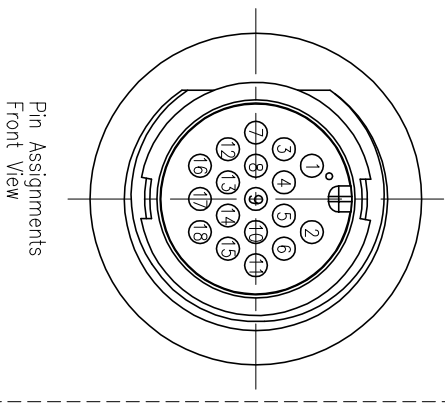
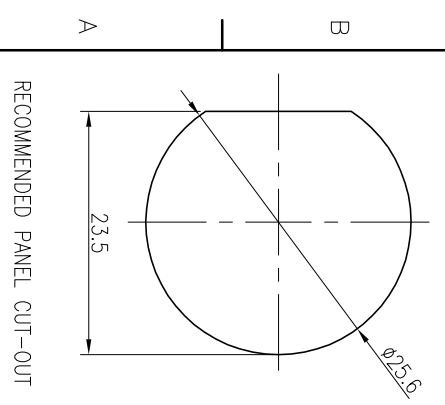
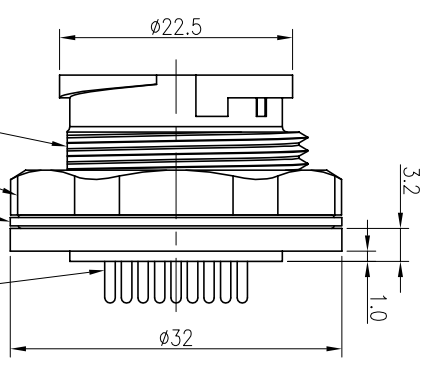
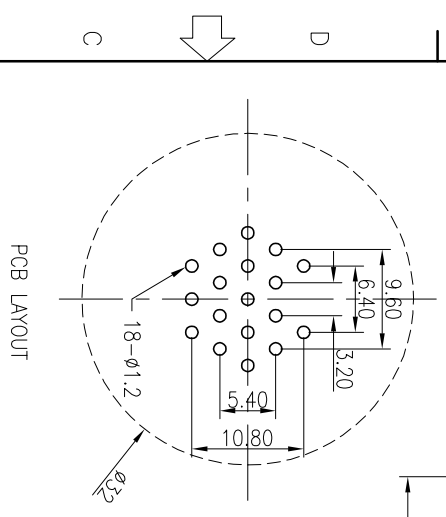
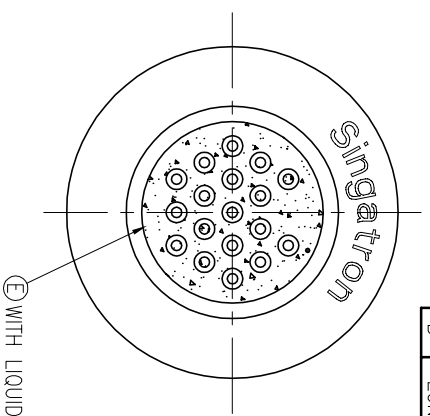
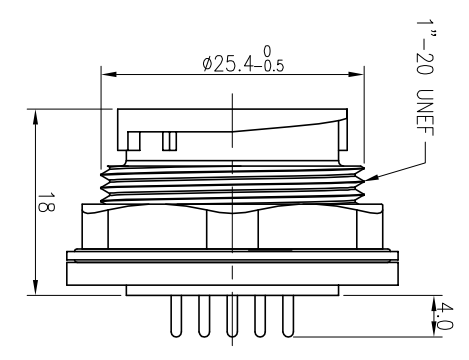

- NOTES:
1. WATERPROOF RATE: IP67
IP67: IMMERSED IN 1M WATER FOR 30 MINUTES
 2. ELECTRICAL CHARACTERISTICS
TEMPERATURE RANGE: -40°C TO +100°C
CURRENT RATING: 5A
 3. DIELECTRIC WITHSTANDING VOLTAGE: 500V AC FOR ONE MINUTE
 4. SPECIFICATIONS:SEE "CIRCULAR SERIES SPECIFICATIONS."
 5. TO CONFORM TO SINGATRON HAZARDOUS SUBSTANCE FREE SPEC.
 6. GREEN PRODUCT IDENTIFICATION LABEL ON PACKAGING: **GR PASS**

E	LIQUID GLUE	1	N/A	BLACK
D	NUT	1	NYLON+33%GF	BLACK
C	GASKET	1	EPDM	BLACK
B	MALE PIN	18	BRASS	6u" GOLD PLATING OVER NICKEL PLATING
A	BODY	1	NYLON+33%GF	BLACK
NO DESCRIPTION		QTY	MATERIAL	PLATING & COLOR
UNLESS OTHERWISE SPECIFIED TOLERANCES				
Singatron Enterprise Co., Ltd. 信營企業股份有限公司				
TITLE: CIRCULAR LARGE SIZE (PCB/LOCK TYPE)				
DWG: YF				
CHKD: Harlen				
APVD: Quon				
PART NO.:2CG3000-W18300				
SCALE: 2:1				
UNIT: mm				
SIZE: A3				
SHEET: 1 OF 1				
REV: B				
CUSTOMER COPY				