

REV.	ECN NO OR DESCRIPTION	REVISED	DATE
A	PDR NO.:T100422-12A	Shown	2010.09.15
B	ECN NO.:S121109	YF	2014.03.27

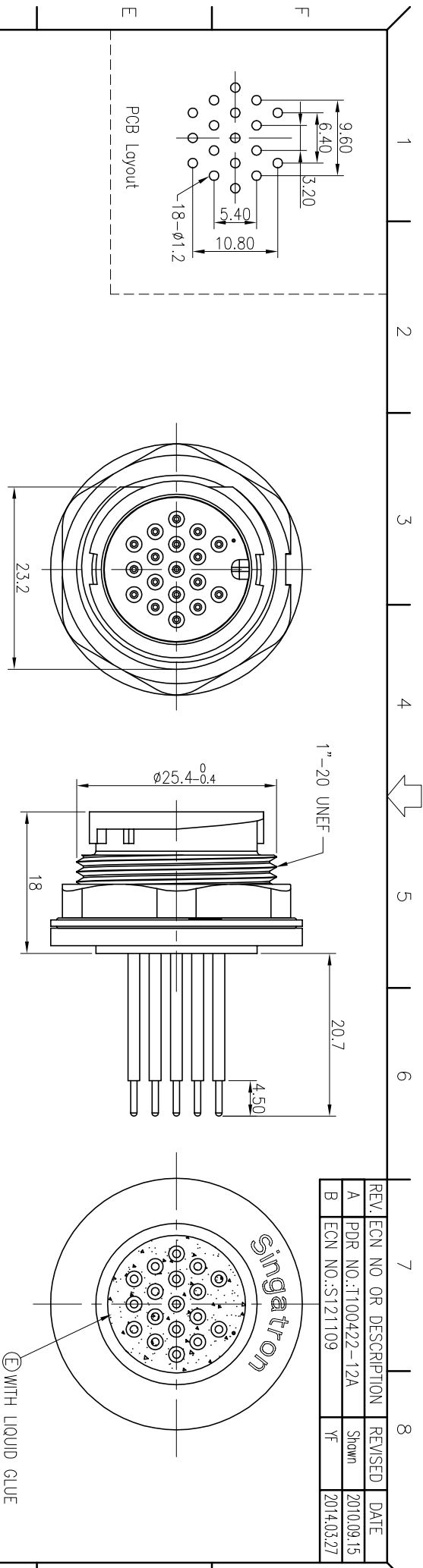

- NOTES:
1. WATERPROOF RATE: IP67
IP67: IMMERSED IN 1M WATER FOR 30 MINUTES
 2. CURRENT RATING: 5A
 3. SPECIFICATIONS:SEE "CIRCULAR SERIES SPECIFICATIONS".
 4. TO CONFORM TO SINGATRON HAZARDOUS SUBSTANCE FREE SPEC.
 5. GREEN PRODUCT IDENTIFICATION LABEL ON PACKAGING: **GR PASS**
 6. FOR PANEL THICKNESS MAX OF 3.5mm

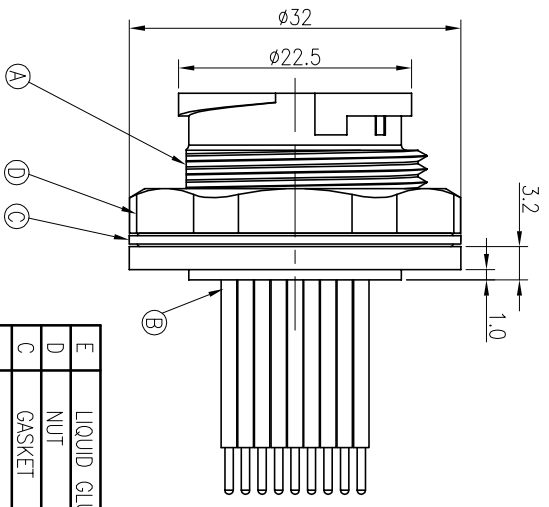
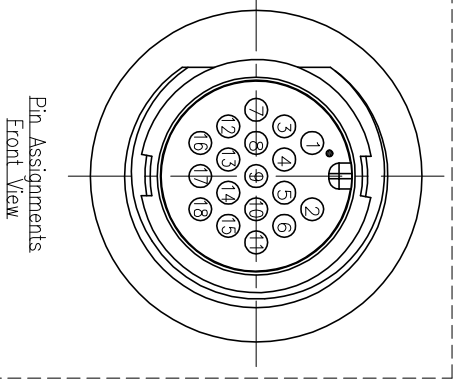
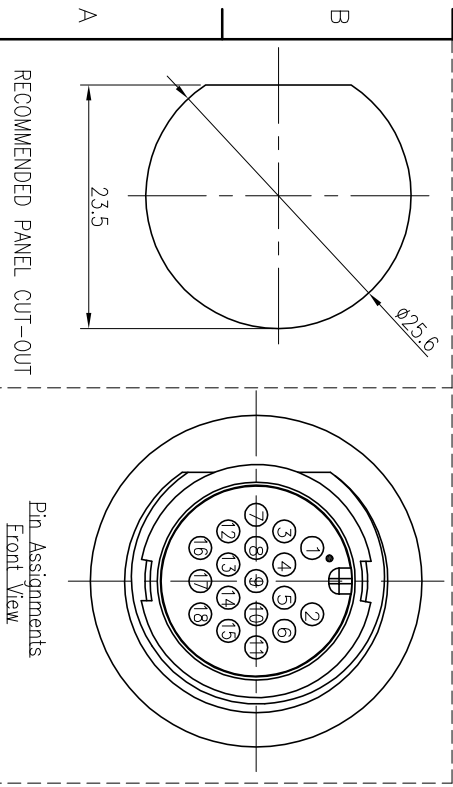

E	LIQUID GLUE	1	N/A	BLACK
D	NUT	1	NYLON+GF	BLACK
C	GASKET	1	EPDM	BLACK
B	MALE PIN	18	BRASS	6u" GOLD PLATING OVER NICKEL PLATING
A	BODY	1	NYLON+GF	BLACK
NO	DESCRIPTION	QTY	MATERIAL	PLATING & COLOR
UNLESS OTHERWISE SPECIFIED TOLERANCES				
Singatron Enterprise Co., Ltd. 信營企業股份有限公司				
TITLE: CIRCULAR LARGE SIZE (PCB/LOCK TYPE)				
SPEC: MALE CONN. MALE 12PIN(SA)				
DECIMALS:	ANGLES:	PART NO.:2CG3000-W18301		
X : ± 0.5	X : $\pm 2^\circ$	CHKD	SCALE 1:1	UNIT: mm
XX : ± 0.3	XX : $\pm 1^\circ$	APVD	Quon	SIZE: A3
XXX : ± 0.2		SHEET:1 OF 1		
REV: B				
CUSTOMER COPY				