

REV.	ECN NO OR DESCRIPTION	REVISED	DATE
A	PDR NO:S150526-4A	JF	2015.11.13

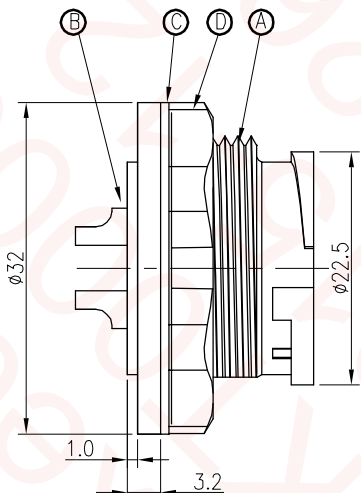

- NOTES:
1. WATERPROOF RATE: IP67(WHEN PROPERLY MATED)  
IP67: IMMERSED IN 1M WATER FOR 30 MINUTES
  2. CURRENT RATING: 20A
  3. TO CONFORM TO SINGATRON HAZARDOUS SUBSTANCE FREE SPEC.
  4. GREEN PRODUCT IDENTIFICATION LABEL ON PACKAGING: **G.P. PASS**
  5. FOR PANEL THICKNESS MAX OF 3.5mm

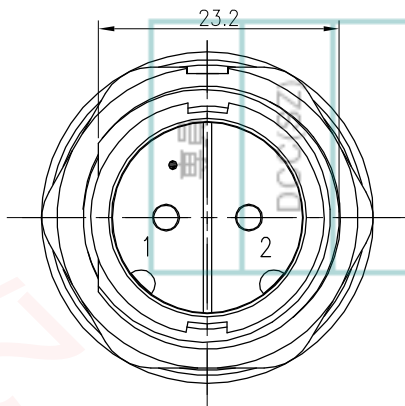
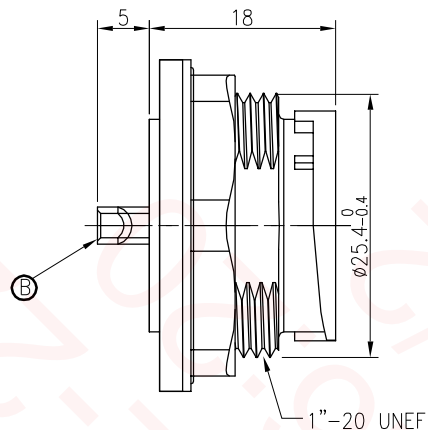
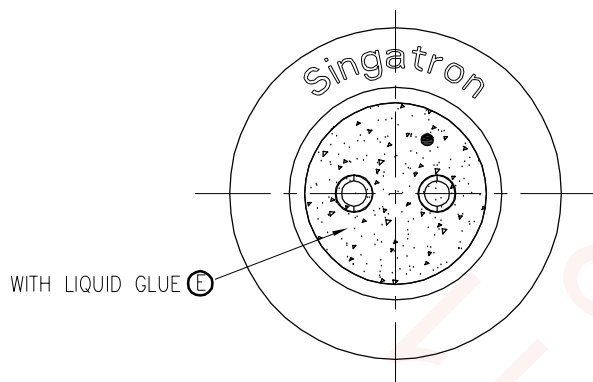
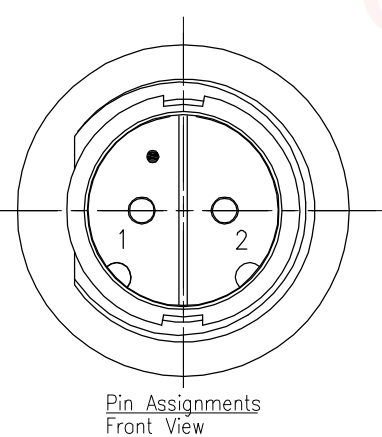
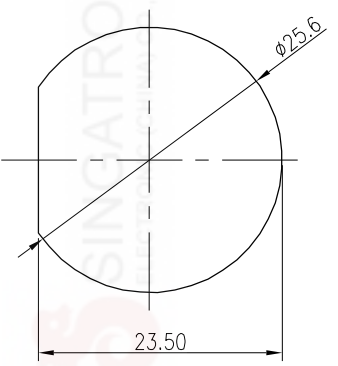

E	LIQUID GLUE	1	N/A	BLACK
D	NUT	1	PA66+GF	BLACK
C	GASKET	1	EPDM	BLACK
B	MALE PIN	2	BRASS	1~3μ" GOLD PLATING OVER NICKEL PLATING
A	BODY	1	PA66+GF	BLACK
NO	DESCRIPTION	QTY	MATERIAL	PLATING & COLOR

UNLESS OTHERWISE SPECIFIED TOLERANCES		Singatron Enterprise Co., Ltd. 信音企業股份有限公司		
DECIMALS:	ANGLES:	TITLE	CIRCULAR LARGE SIZE (SOLDER/LOCK TYPE) MALE CONN. MALE 2PIN(20A)	
X : ±0.5	X : ±2°	DWN	JF	<b>PART NO.2CG3002-W02600H</b>
X.X : ±0.3	X.X : ±1'	CHKD	Yang	SCALE 2:1 UNIT: mm
X.XX : ±0.2		APVD	Harlen	SIZE: A3 SHEET:1 OF 1 REV: A
<b>CUSTOMER COPY</b>				

