

- NOTES:
1. WATERPROOF RATE: IP67 (WHEN PROPERLY MATED)
IP67: IMMERSED IN 1M WATER FOR 30 MINUTES
 2. TEST CONDITIONS:
 - 2-1. SHORT/OPEN CONDUCT TEST
 - 2-2. HI-POT TEST 500VAC, 5mA (1SEC)
 - 2-3. INSULATION RESISTANCE: 100MD MIN. BY 500 VDC
 - 2-4. OTHER GENERAL SPEC. TO REFER "CIRCULAR SERIES SPEC".
 3. TO CONFORM TO SINGATRON HAZARDOUS SUBSTANCE FREE SPEC.
 4. GREEN PRODUCT IDENTIFICATION LABEL ON PACKAGING: **[G.P. PASS]**
 5. FOR PANEL THICKNESS MAX OF 3.5mm

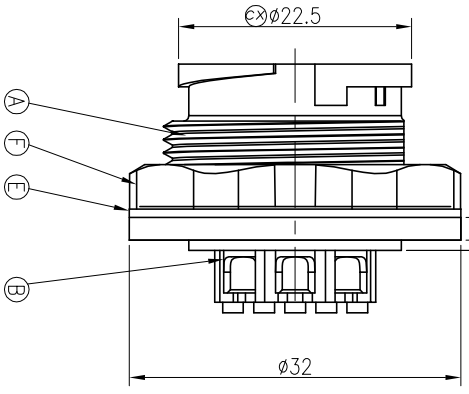
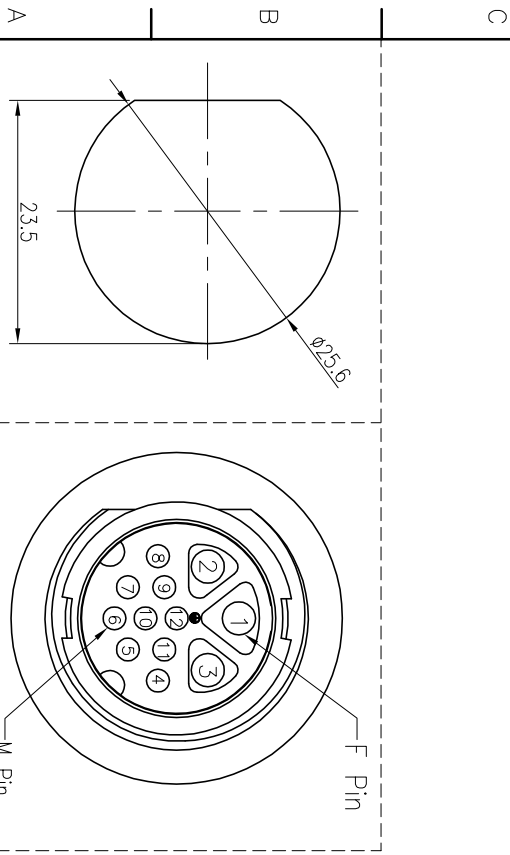

RECOMMENDED PANEL CUT-OUT

Pin Assignments
Front View

REV.	ECN NO OR DESCRIPTION	REVISED	DATE
A	PDR NO.:C100121-2A	Joe-Iloo	2010.01.26
B	ECN NO.:S121109	YF	2014.03.27

G	LIQUID GLUE	1	N/A	BLACK
F	NUT	1	NYLON+33%GF	BLACK
E	GASKET	1	EPDM	BLACK
D	SHORT MALE PIN	4	BRASS	6u" GOLD PLATING OVER NICKEL PLATING
C	LONG MALE PIN	5	BRASS	6u" GOLD PLATING OVER NICKEL PLATING
B	FEMALE PIN	3	Phosphor Bronze	GOLD FLASH OVER NICKEL PLATING
A	BODY	1	NYLON+33%GF (70G33L)	BLACK
NO DESCRIPTION		QTY	MATERIAL	PLATING & COLOR
UNLESS OTHERWISE SPECIFIED TOLERANCES				
Singatron Enterprise Co., Ltd. 信營企業股份有限公司				
CIRCULAR LARGE SIZE (SOLDER LOCK TYPE)				
TITLE		PART NO.:2CG3002-W12P00		
DWG		SCALE 2:1		
CHKD		UNIT: mm		
APVD		SHEET: 1 OF 1		
SIZE: A3 SHEET: 1 OF 1 REV: B CUSTOMER COPY				