

REV.	ECN NO OR DESCRIPTION	REVISED	DATE
A	PDR NO.:S120705-5B	Shown	2013.08.05

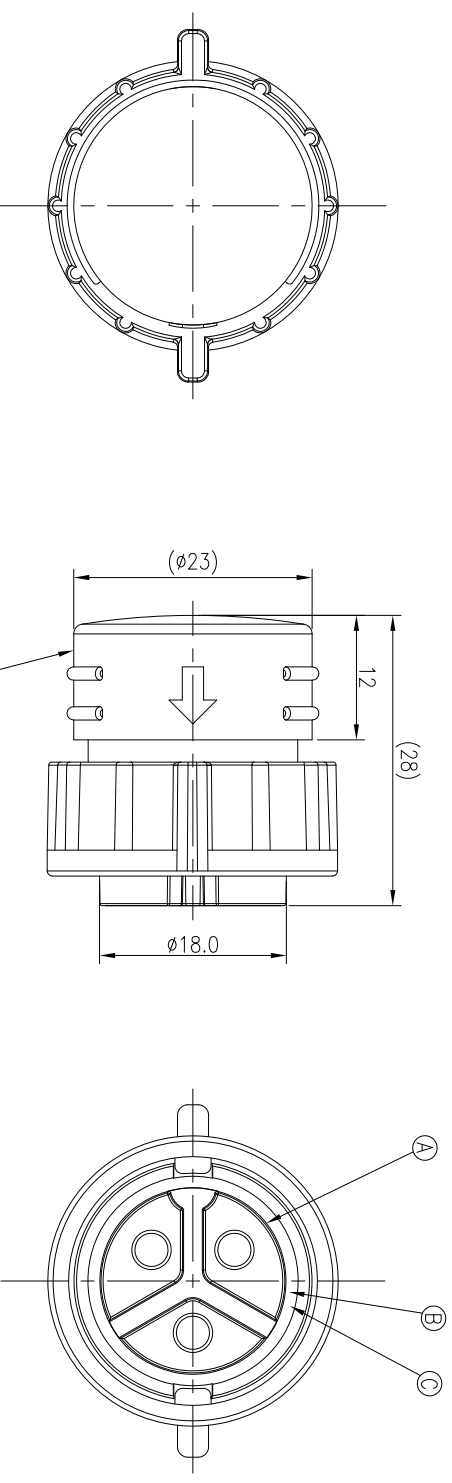

- NOTES:
1. WATERPROOF RATE: IP67
IP67: IMMersed IN 1M WATER FOR 30 MINUTES
 2. TO CONFORM TO SINGATRON HAZARDOUS SUBSTANCE FREE SPEC.
 3. GREEN PRODUCT IDENTIFICATION LABEL ON PACKAGING: **GR-PASS**

NO	DESCRIPTION	QTY	MATERIAL	PLATING & COLOR
E	OVER MOLD	1	PVC	BLACK
D	INNER MOLD	1	PVC	BLACK
C	O-RING	1	EPDM	BLACK
B	LOCK NUT	1	PC 9330	BLACK
A	BODY	1	PA66+30%GF 94V-0	BLACK

UNLESS OTHERWISE SPECIFIED TOLERANCES

DECIMALS:	ANGLES:
X :±0.5	X :±2°
XX :±0.3	XX :±1°
X.XX :±0.2	

TITLE	SCALE	SHEET	REV.
LARGE SIZE WATERPROOF CAP (FEMALE)	2:1	1 OF 1	A

信亨企業股份有限公司 Singatron Enterprise Co., Ltd.

CUSTOMER COPY