

REV.	ECN NO OR DESCRIPTION	REVISED	DATE
A	PDR NO.:T110905-3A	Shown	2011.12.10
B	ECN NO.:S120821	JF	2012.08.09
C	ECN NO.:S121109	YF	2014.03.28

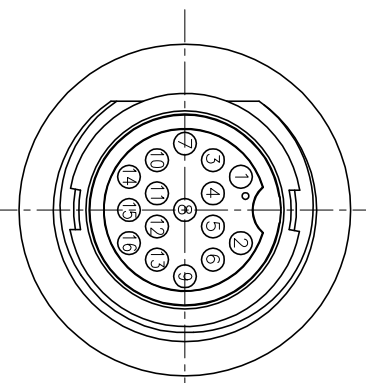
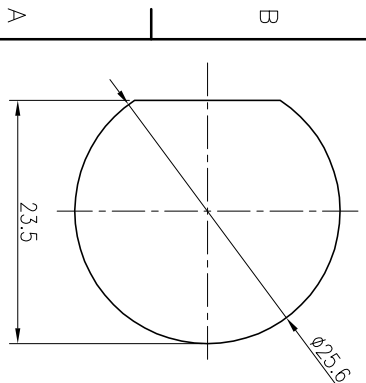
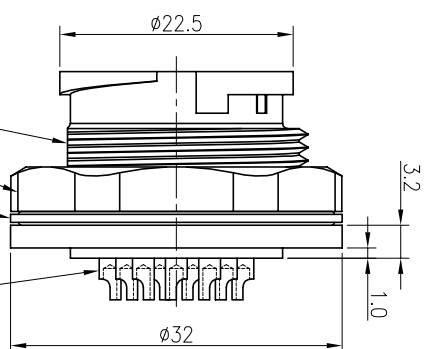
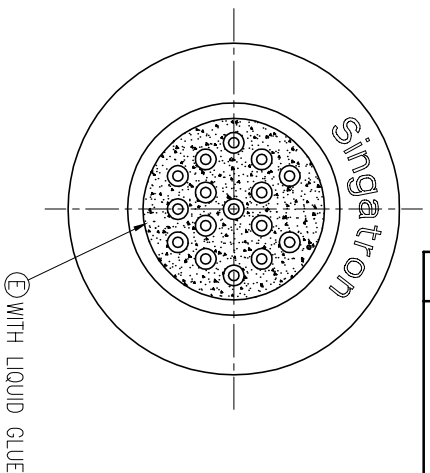
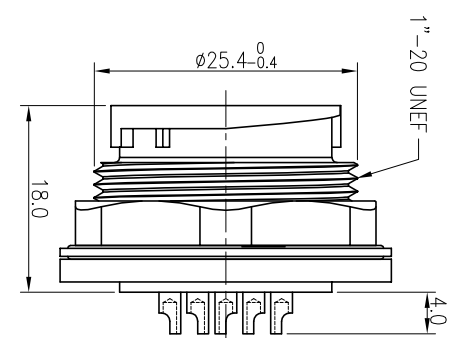
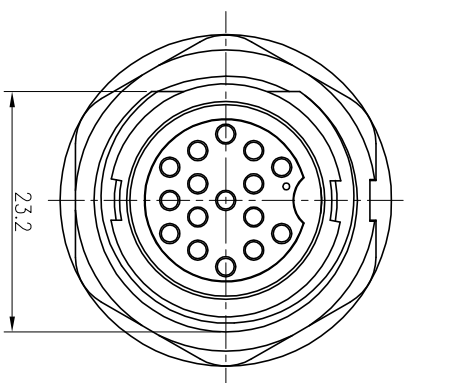

- NOTES:
1. WATERPROOF RATE: IP67  
IP67: IMMersed IN 1M WATER FOR 30 MINUTES
  2. ELECTRICAL CHARACTERISTICS  
TEMPERATURE RANGE: -40°C TO +100°C  
CURRENT RATING: 5A
  3. DIELECTRIC WITHSTANDING VOLTAGE: 500V AC FOR ONE MINUTE
  4. SPECIFICATIONS:SEE "CIRCULAR SERIES SPECIFICATIONS."
  5. TO CONFORM TO SINGATRON HAZARDOUS SUBSTANCE FREE SPEC.
  6. GREEN PRODUCT IDENTIFICATION LABEL ON PACKAGING: **GR-PASS**

NO	DESCRIPTION	QTY	MATERIAL	PLATING & COLOR
E	LIQUID GLUE	1	N/A	BLACK
D	NUT	1	NYLON+33%GF	BLACK
C	GASKET	1	EPDM	BLACK
B	FEMALE PIN	16	Phosphor Bronze	6u" GOLD PLATING OVER NICKEL PLATING
A	BODY	1	NYLON+33%GF	BLACK

UNLESS OTHERWISE SPECIFIED TOLERANCES

Singatron Enterprise Co., Ltd.  
信營企業股份有限公司

CIRCULAR LARGE SIZE (SOLDER/LOCK TYPE)  
TITLE MALE CONN. FEMALE 16PIN(S4)

DECIMALS:	ANGLES:	TITLE	PART NO.	SCALE	UNIT:	SHEET:	REV:
X :±0.5	X :±2°	DMN	YF	2.1	mm	1 OF 1	C
XX :±0.3	XX :±1'	CHKD	Harlen				
XXX :±0.2		APVD	Quon				

RECOMMENDED PANEL CUT-OUT

PIN ASSIGNMENTS FRONT VIEW

CUSTOMER COPY