

REV.	ECN NO OR DESCRIPTION	REVISED	DATE
A	PDR NO.:C100121-2A	Shawn	2010.09.27
B	EVN NO.:S101246	Shawn	2010.12.28

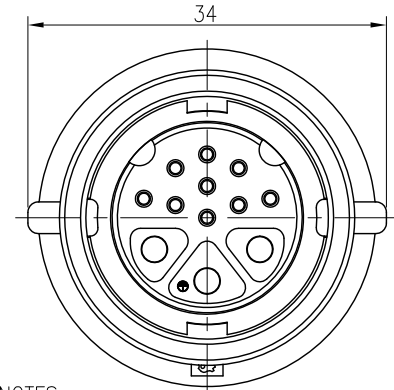

- NOTES:
1. WATERPROOF RATE: IP67(WHEN PROPERLY MATED)
IP67: IMMERSED IN 1M WATER FOR 30 MINUTES
 2. TEST CONDITIONS:
 - 2-1. CONTACT RESISTANCE: 3 Ohm Max.
 - 2-2. HI-POT TEST 500VAC,5mA(1SEC)
 - 2-3. INSULATION RESISTANCE: 100MΩ MIN. BY 500 VDC
 - 2-4. OTHER GENERAL SPEC. TO REFER "CIRCULAR SERIES SPEC".
 3. TO CONFORM TO SINGATRON HAZARDOUS SUBSTANCE FREE SPEC.
 4. GREEN PRODUCT IDENTIFICATION LABEL ON PACKAGING: **G.P. PASS**
 5. FOR PANEL THICKNESS MAX OF 3.5mm

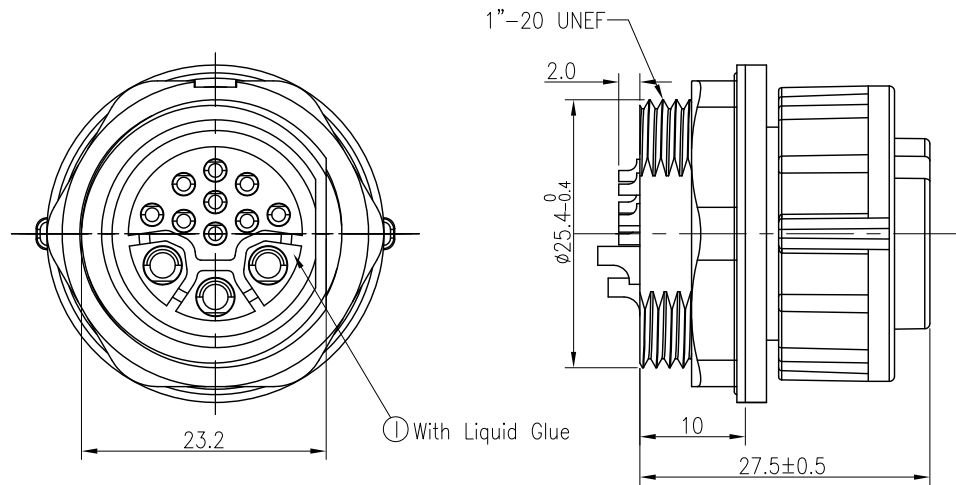
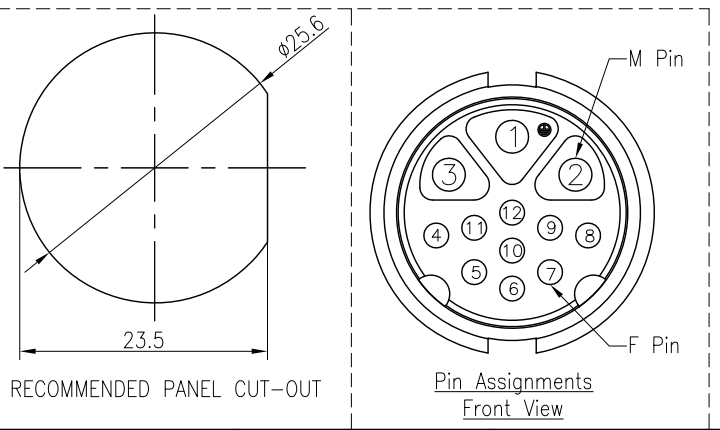
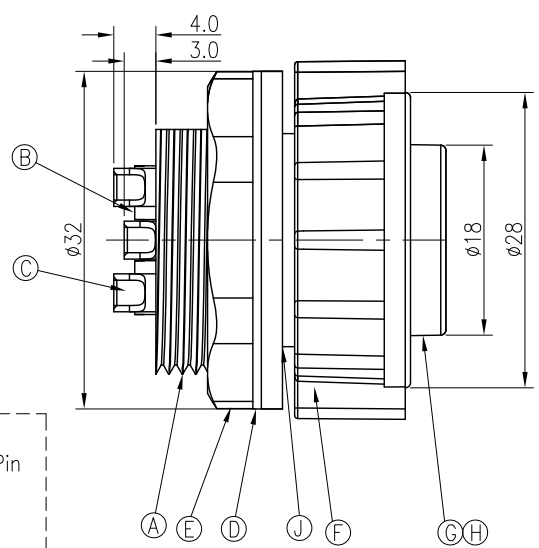

NO	DESCRIPTION	QTY	MATERIAL	PLATING & COLOR
J	O-RING-2	1	EPDM	BLACK
I	LIQUID GLUE	1	N/A	BLACK
H	O-RING-1	1	EPDM	BLACK
G	BODY	1	NYLON+GF	BLACK
F	LOCK NUT	1	NYLON+GF	BLACK
E	SCREW NUT	1	NYLON+GF	BLACK
D	GASKET	1	EPDM	BLACK
C	MALE PIN	3	BRASS	GOLD FLASH OVER NICKEL PLATING
B	FEMALE PIN	9	Phosphor Bronze	6uin GOLD PLATING OVER NICKEL PLATING
A	HOUSING	1	NYLON+GF	BLACK

UNLESS OTHERWISE SPECIFIED TOLERANCES

Singatron Enterprise Co., Ltd.
信音企業股份有限公司

TITLE	CIRCULAR LARGE SIZE (SOLDER/LOCK TYPE) FEMALE CONN. FEMALE 12PIN(S+20A)		
DWN	Shawn	PART NO.2CG3037-W12F00	
CHKD	Steve	SCALE 2:1	UNIT: mm
APVD	Quan	SIZE: A3	SHEET: 1 OF 1

REV: B

CUSTOMER COPY