

REV.	ECN NO OR DESCRIPTION	REVISED	DATE
A	PDR NO.:T101109-21A	Shown	2011.12.03
B	ECN NO.:S121109	YF	2014.03.27

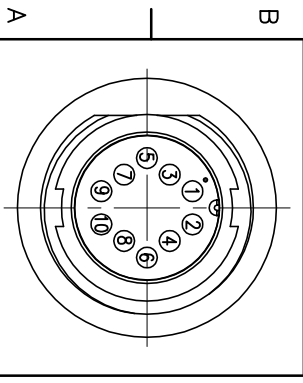
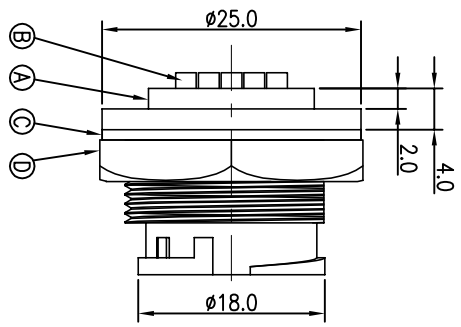
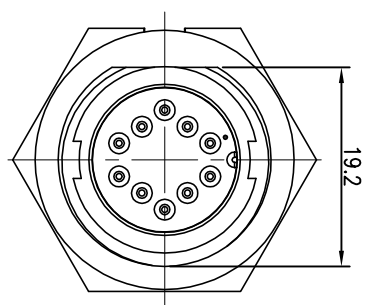
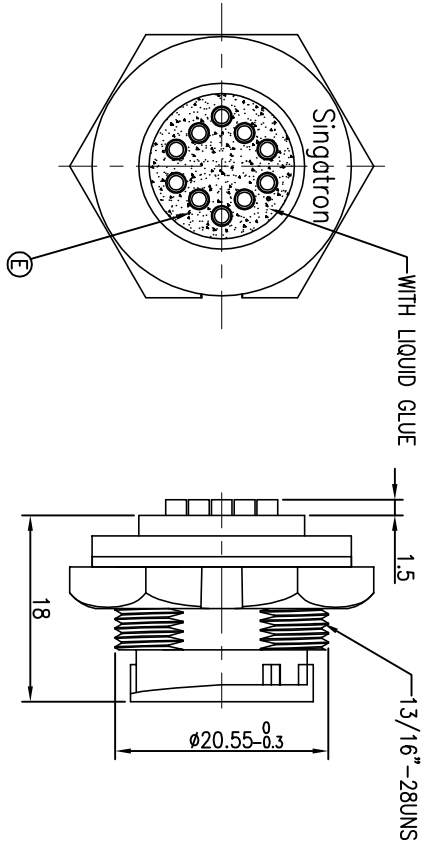
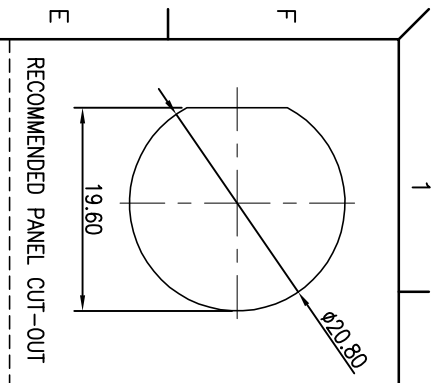

- NOTES:
1. WATERPROOF RATE: IP67
IP67: IMMERSED IN 1M WATER FOR 30 MINUTES
 2. ELECTRICAL CHARACTERISTICS
TEMPERATURE RANGE: -40°C TO +100°C
CURRENT RATING: 5A
 3. SPECIFICATIONS:SEE "CIRCULAR SERIES SPECIFICATIONS".
 4. TO CONFORM TO SINGATRON HAZARDOUS SUBSTANCE FREE SPEC.
 5. GREEN PRODUCT IDENTIFICATION LABEL ON PACKAGING:
 6. FOR PANEL THICKNESS MAX OF 3.5mm

E	LIQUID GLUE	1	N/A	BLACK
D	NUT	1	NYLON+33%GF	BLACK
C	GASKET	1	EPDM	BLACK
B	MALE PIN	10	BRASS	6u" GOLD PLATING OVER NICKEL PLATING
A	BODY	1	NYLON+33%GF	BLACK
UNLESS OTHERWISE SPECIFIED TOLERANCES				
Singatron Enterprise Co., Ltd. 信營企業股1分有限公司 CIRCULAR MIDDLE SIZE (SOLDER/LOCK TYPE) TITLE MALE CONN. MALE TOPIN(SA)				
DECIMALS:		ANGLES:		
X	:±0.5	X	:±2°	
XX	:±0.3	XX	:±1'	
XXX	:±0.2			
APVD Quon		SCALE 2:1	UNIT: mm	REV: B
SIZE: A3 SHEET:1 OF 1				
CUSTOMER COPY				