

| REV. | ECN NO. | OR DESCRIPTION | REVISED | DATE |
|------|--------------------|----------------|---------|------------|
| A | PDR NO.:T151125-3A | Vicky | | 2015.11.26 |

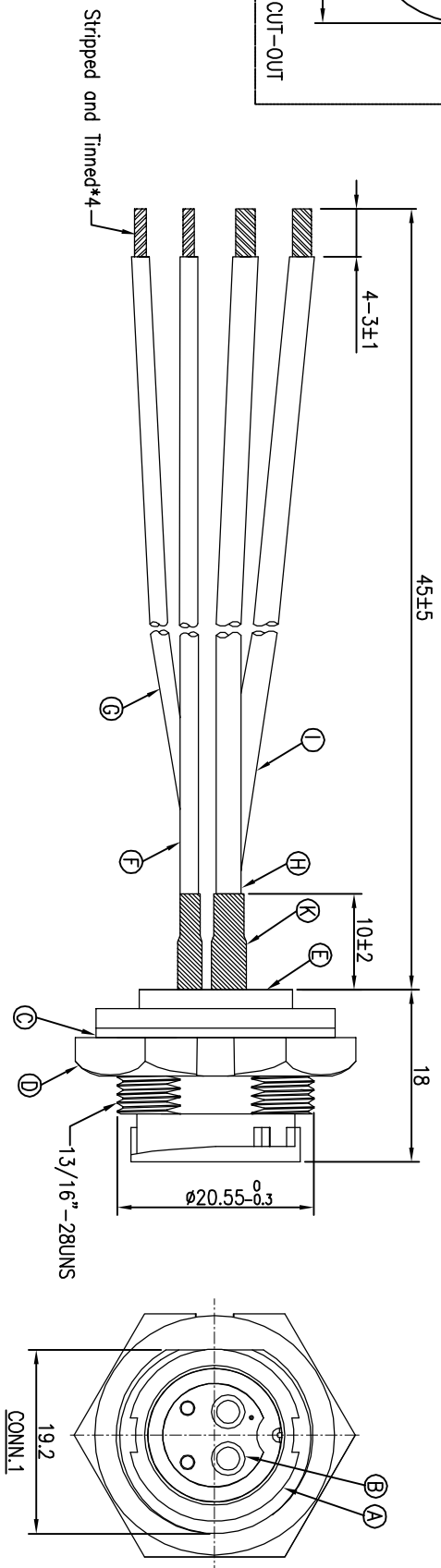

| | |
|-------|--------|
| GREEN | 4 |
| WHITE | 3 |
| BLACK | 2 |
| RED | 1 |
| WIRE | CONN.1 |

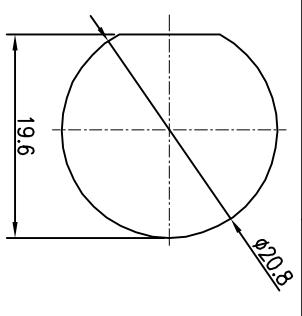
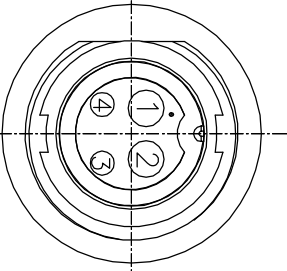

- NOTES:
1. WATERPROOF RATE: IP67
IP67: IMMERSED IN 1M WATER FOR 30 MINUTES
 2. ELECTRICAL CHARACTERISTICS
TEMPERATURE RANGE:-20°C TO +80°C
CURRENT RATING: 2+16A
DIELECTRIC WITHSTANDING VOLTAGE: 500V AC FOR ONE MINUTE
 3. SPECIFICATIONS:SEE "CIRCULAR SERIES SPECIFICATIONS".
 4. TO CONFORM TO SINGATRON HAZARDOUS SUBSTANCE FREE SPEC.
 5. GREEN PRODUCT IDENTIFICATION LABEL ON PACKAGING:
 6. FOR PANEL THICKNESS MAX OF 3.5mm

| | | | | |
|---|------------------|---|------------------|---|
| K | HEAT SHRINK TUBE | 2 | Ø3.0mm 300V 125° | BLACK |
| J | HEAT SHRINK TUBE | 2 | Ø4.0mm 300V 125° | BLACK |
| I | WIRE | 1 | UL1015 14AWG | BLACK |
| H | WIRE | 1 | UL1015 14AWG | RED |
| G | WIRE | 1 | UL10368 20AWG | WHITE |
| F | WIRE | 1 | UL10368 20AWG | GREEN |
| E | LIQUID GLUE | 1 | N/A | BLACK |
| D | NUT | 1 | NYLON+GF | BLACK |
| C | GASKET | 1 | EPDM | BLACK |
| B | FEMALE PIN | 4 | Phosphor Bronze | 6u" GOLD PLATING OVER NICKEL PLATING |
| A | BODY | 1 | NYLON+GF | BLACK |

UNLESS OTHERWISE SPECIFIED TOLERANCES

| | |
|------------|----------|
| DECIMALS: | ANGLES: |
| X :±0.5 | X :±2° |
| X.X :±0.3 | X.X :±1° |
| X.XX :±0.2 | |

Singatron Enterprise Co., Ltd.
 信亨企業股份有限公司
 TITLE: CIRCULAR MIDDLE SIZE LOCK TYPE
 DWG: Vicky PART NO. 2CM3014-W04B02H
 CHKD: Harlen SCALE 2:1 UNIT: mm
 APVD: Steve SIZE: A3 SHEET: 1 OF 1 REV: A

CUSTOMER COPY