

REV.	ECN NO OR DESCRIPTION	REVISED	DATE
A	PDR NO.:T091002-4A	Harfen	2009.09.10
B	ECN NO.:S121109	YF	2014.03.27

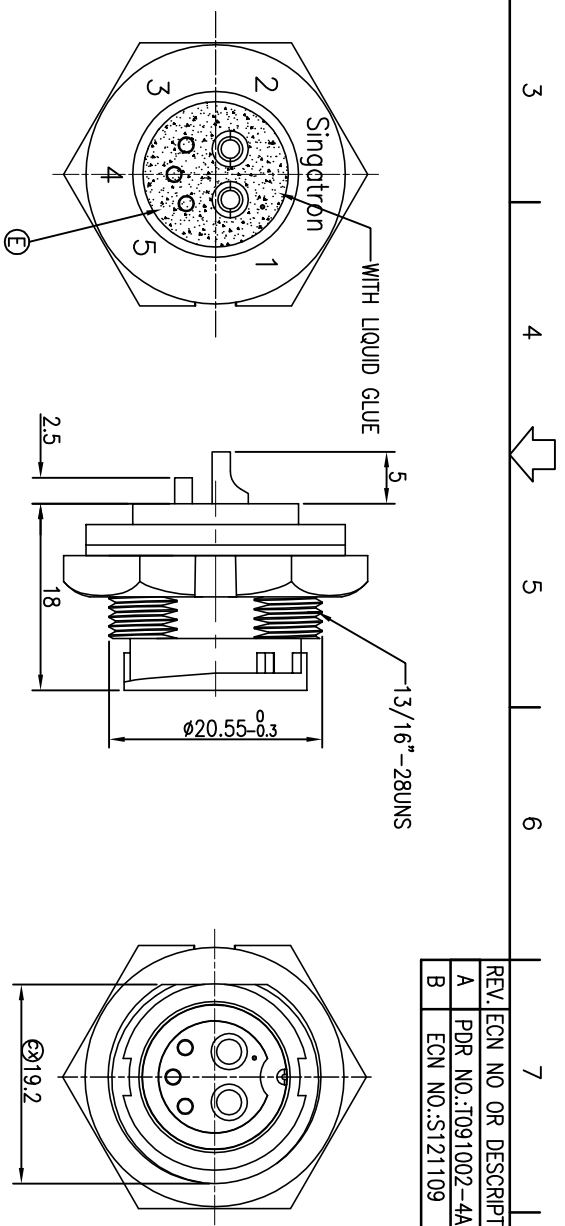

PIN ASSIGNMENTS
FRONT VIEW

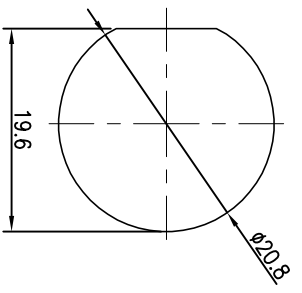

RECOMMENDED PANEL CUT-OUT

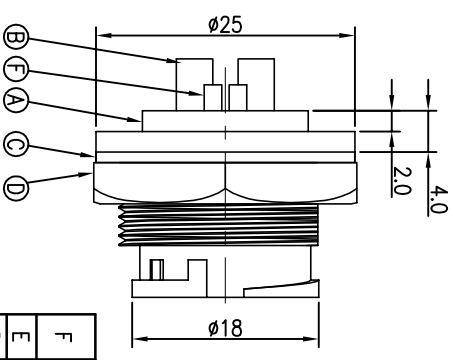

- NOTES:
1. WATERPROOF RATE: IP67
IP67: IMMERSED IN 1M WATER FOR 30 MINUTES
 2. ELECTRICAL CHARACTERISTICS
TEMPERATURE RANGE: -40°C TO +100°C
CURRENT RATING: 2+16A
 3. SPECIFICATIONS: SEE "CIRCULAR SERIES SPECIFICATIONS".
 4. TO CONFORM TO SINGATRON HAZARDOUS SUBSTANCE FREE SPEC.
 5. GREEN PRODUCT IDENTIFICATION LABEL ON PACKAGING:
 6. FOR PANEL THICKNESS MAX OF 3.5mm

NO	DESCRIPTION	QTY	MATERIAL	PLATING & COLOR
F	FEMALE PIN	3	Phosphor Bronze	6u" GOLD PLATING OVER NICKEL PLATING
E	LIQUID GLUE	1	N/A	BLACK
D	NUT	1	NYLON+GF	BLACK
C	GASKET	1	EPDM	BLACK
B	FEMALE PIN	2	Phosphor Bronze	6u" GOLD PLATING OVER NICKEL PLATING
A	BODY	1	NYLON+GF	BLACK

UNLESS OTHERWISE SPECIFIED TOLERANCES

Singatron Enterprise Co., Ltd.
 信益企業股份有限公司

TITLE: CIRCULAR MIDDLE SIZE (LOCK TYPE)
 MALE CONN. FEMALE 5 PIN(2+16A)

DMN	YF	PART NO. 2CM3014-W05B00
CHKD	Harfen	SCALE 2:1 UNIT: mm
APVD	Quon	SIZE: A3 SHEET: 1 OF 1 REV: B

CUSTOMER COPY