

REV.	ECN NO.	OR DESCRIPTION	REVISED	DATE
A	PDR NO.:S100118-1G	LILY		2010.04.19
B	ECN NO.:S110408	LILY		2011.05.24

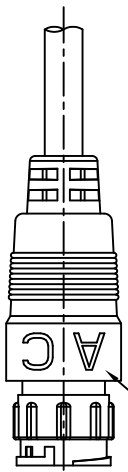

YELLOW/GREEN	3
BLUE	2
BROWN	1
WIRE COLOR	CONN.
PIN OUT	

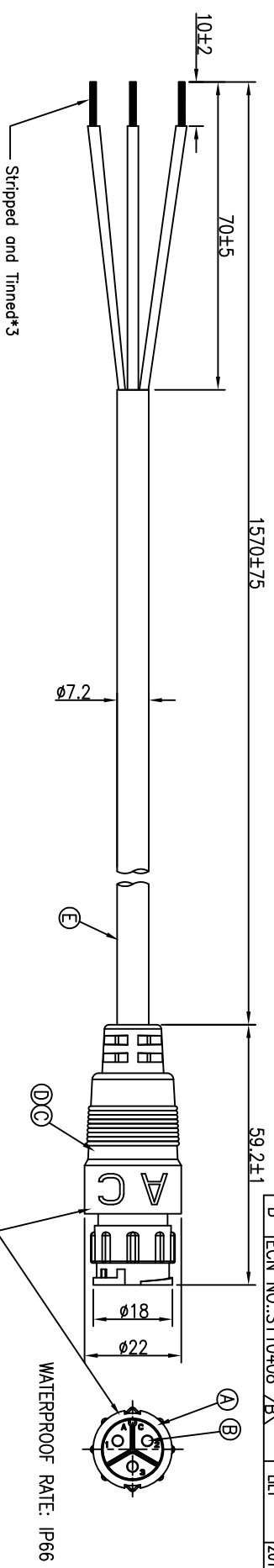
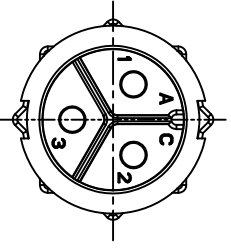

Pin Assignments
Front View

- NOTES:
1. WATERPROOF RATE: IP66
 2. CURRENT RATING: 10A
 3. SPECIFICATIONS:SEE "CIRCULAR SERIES SPECIFICATIONS".
 4. TO CONFORM TO SINGATRON HAZARDOUS SUBSTANCE FREE SPEC.
 5. GREEN PRODUCT IDENTIFICATION LABEL ON PACKAGING:

NO	DESCRIPTION	QTY	MATERIAL	PLATING & COLOR
E	CABLE	1	245 IEC 57(YZW) 3*1mm ² (UV RESISTANT)	BLACK
D	INNER MOLD	1	ABS 94V-0	NATURAL
C	OVER MOLD	1	PVC VW-1	BLACK
B	MALE PIN	3	BRASS	(1~3)u" GOLD PLATING OVER NICKEL PLATING
A	BODY	1	NYLON+30%GF 94V-0	BLACK

UNLESS OTHERWISE SPECIFIED TOLERANCES

Singatron Enterprise Co., Ltd.
信益企業股份有限公司

DECIMALS:	ANGLES:
X :±0.5	X :±2°
X.X :±0.3	X.X :±1°
X.XX :±0.2	

TITLE	CIRCULAR MIDDLE SIZE (IP66) MALE CONN. MALE 3 PIN LOCK TYPE
DWN	LILY
CHKD	Stewe
APVD	Quan
PART NO.	2CM3024-W03402
SCALE	1:1
UNIT	mm
SIZE	A3
SHEET	1 OF 1
REV.	B

CUSTOMER COPY