

REV.	ECN NO.	OR DESCRIPTION	REVISED	DATE
A	PDR NO.:	S131125-8C	Shown	2014.05.09
B	ECN NO.:	S141261/A	LIN	2015.04.07

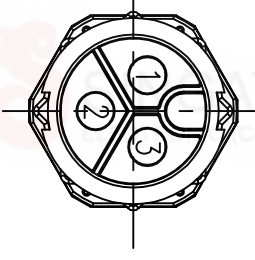
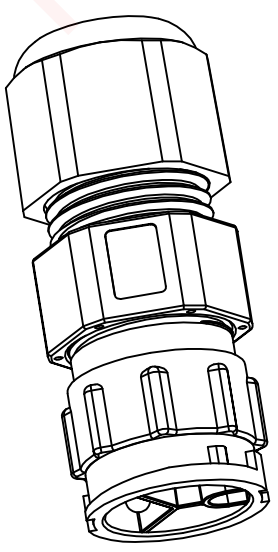
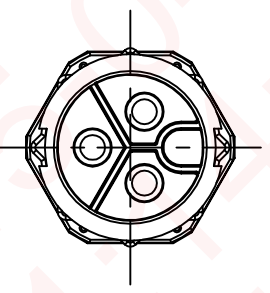
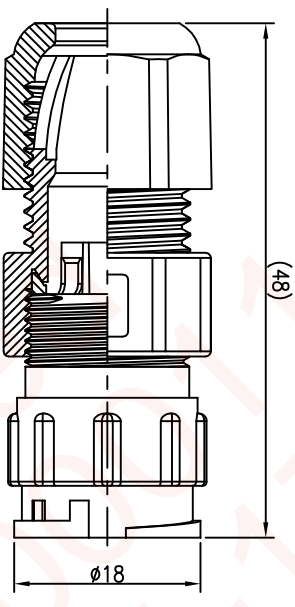
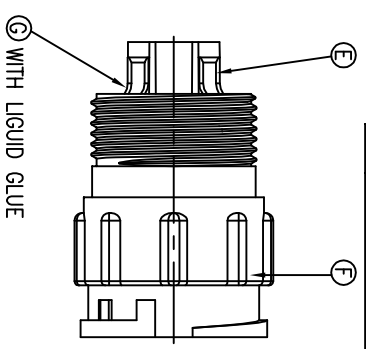
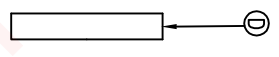
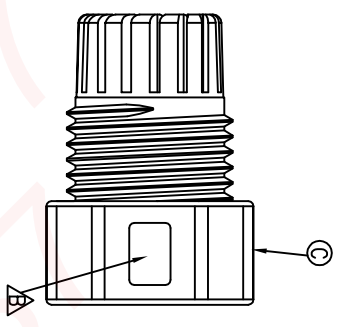
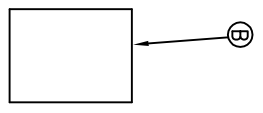
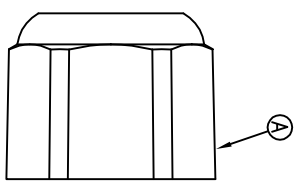

Pin Assignments
Front View

- NOTES:
- ELECTRICAL CHARACTERISTICS:
 - 1-1 CURRENT RATING: 20 AMPS.
 - 1-2 CONTACT RESISTANCE: 30 mOhm Max.
 - 1-3 INSULATION RESISTANCE: 100 Mohm Min. at 500VDC.
 - 1-4 BREAKDOWN VOLTAGE: 1000 VAC PER MINUTE.
 - MECHANICAL CHARACTERISTICS:
 - 2-1 TIGHTENING TORQUES: 1.0~1.2Nm(8.85~10.62lbf.in.).
 - 2-2 MECHANICAL CHARACTERISTICS: CONTACT ACCOMMODATION: 14~16 AWG.
 - ENVIRONMENTAL:
 - 3-1 OPERATING TEMPERATURE: -40°C TO +105°C.
 - 3-2 SEALING REQUIREMENTS: P67.
 - SEAL FOR CABLE OD: $\phi 6.0\text{mm} \sim \phi 9.0\text{mm}$.
 - LIFE TEST: 1,000 CYCLES MIN.
 - OTHER GENERAL SPEC TO REFER "CIRCULAR SERIES GENERAL SPEC"
 - FOR TECHNICAL DATA REFER TO YOUR LOCAL SINGATRON ELECTRONICS SALES OFFICE.
 - ALL DIMENSIONS ARE NOMINAL FOR REFERENCE ONLY UNLESS OTHERWISE STATED.
 - TO CONFORM TO SINGATRON HAZARDOUS SUBSTANCE FREE SPEC.
 - GREEN PRODUCT IDENTIFICATION LABEL ON PACKAGING. RoHS PASS

G	LIQUID GLUE	1	N/A	BLACK
F	BODY	1	PA66+GF	BLACK
E	MALE PIN	3	BRASS	1~3u" GOLD PLATING OVER NICKEL PLATING
D	GASKET	1	SILICONE	BLACK
C	CLAMP RING	1	PC	BLACK
B	SEAL	1	EPDM	BLACK
A	SEALING NUT	1	PA66	BLACK
NO	DESCRIPTION	QTY	MATERIAL	PLATING & COLOR

UNLESS OTHERWISE SPECIFIED TOLERANCES

DECIMALS:	ANGLES:
X :±0.5	X :±2
X.X :±0.3	X.X :±1'
X.XX :±0.2	

Singatron Enterprise Co., Ltd.
 信晉企業股份有限公司
 TITLE: CIRCULAR MIDDLE SIZE (P67) ASSEMBLY
 MALE CONN. MALE 3 PIN LOCK TYPE
 DWG: LIN PART NO.: 2CM3033-W03601H
 CHKD: Yang SCALE: 2:1 UNIT: mm
 APVD: Harden SIZE: A3 SHEET: 1 OF 1 REV: B

CUSTOMER COPY