

REV. A	ECN NO. OR DESCRIPTION PDR NO.:1090714-1A	REVISED Steve	DATE 2009.07.13
--------	--	------------------	--------------------

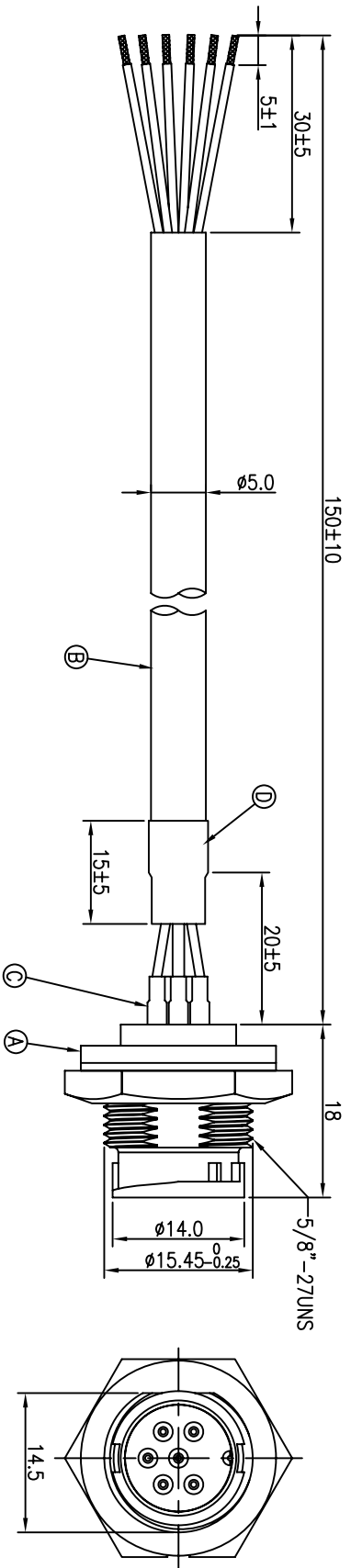

- NOTES:
1. WATERPROOF RATE: IP67
 2. IP67: IMMERSED IN 1M WATER FOR 30 MINUTES
 3. TO CONFORM TO SINGATRON HAZARDOUS SUBSTANCE FREE SPEC.
 4. GREEN PRODUCT IDENTIFICATION LABEL ON PACKAGING: [CSP-PASS]
 5. FOR PANEL THICKNESS MAX OF 4.0mm
- CURRENT RATING: 5A
 BREAKDOWN VOLTAGE: AC 500V/1MINUTE NO BREAKDOWN

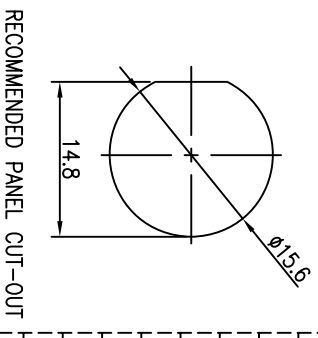
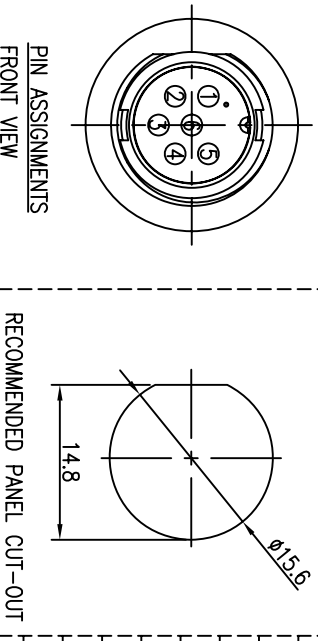

WIRE COLOR	PIN OUT
WHITE	6
RED	5
BLACK	4
YELLOW	3
GREEN	2
BLUE	1

NO	DESCRIPTION	QTY	MATERIAL	PLATING & COLOR
D	SHRINK TUBE	1	Ø5*15	BLACK
C	SHRINK TUBE	6	Ø2*7	BLACK
B	CABLE	1	UL2464 24#*6C+AL UV RESISTANT	BLACK PVC JACKET
A	CONNECTOR	1	P/N:2CT3002-W06300	BLACK

UNLESS OTHERWISE SPECIFIED TOLERANCES

DECIMALS:	ANGLES:
X :±0.5	X :±2°
X.X :±0.3	X.X :±1°
X.XX :±0.2	

Singatron Enterprise Co., Ltd.
 信普企業股份有限公司
 CIRCULAR STANDARD SIZE (SOLDER/LOCK TYPE)
 MALE CONN. MALE 6PIN (5A)

CHKD	Quon	SCALE 2:1	UNIT: mm	REV: A
APVD	Max	SIZE: A3	SHEET: 1 OF 1	

CUSTOMER COPY