

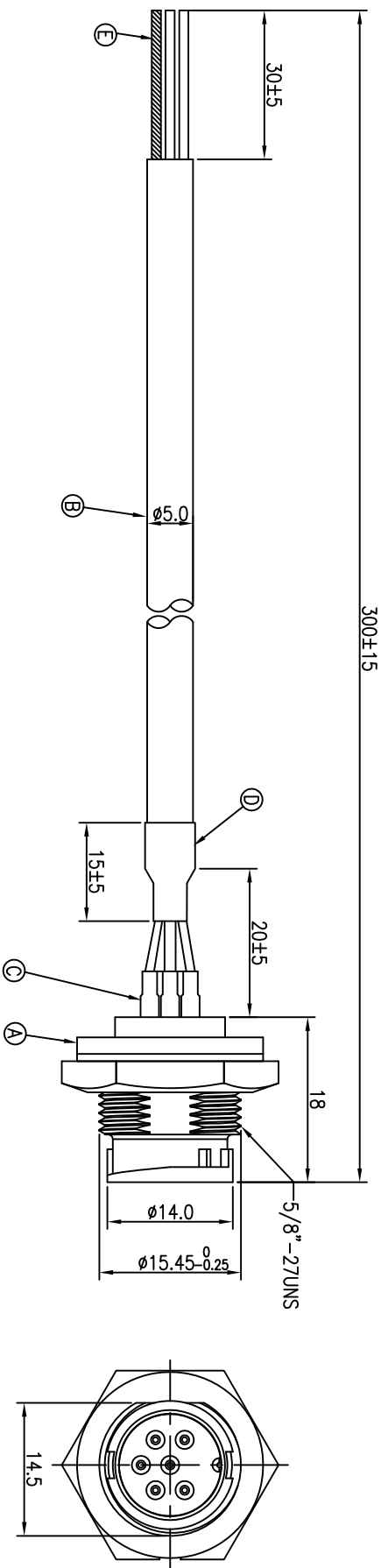

REV.	ECN NO. OR DESCRIPTION	REVISED	DATE
A	PDR NO.:T100826-5A	LILY	2010.09.29
B	ECN NO.:S110103	LILY	2011.02.15



6	
5	DRAIN+BRAID
4	
3	GREEN
2	BLUE
1	WIRE COLOR
	CONN.

- NOTES:
1. WATERPROOF RATE: IP67
 2. CURRENT RATING: 5A
 3. TO CONFORM TO SINGATRON HAZARDOUS SUBSTANCE FREE SPEC.
 4. GREEN PRODUCT IDENTIFICATION LABEL ON PACKAGING: 
 5. FOR PANEL THICKNESS MAX OF 4.0mm

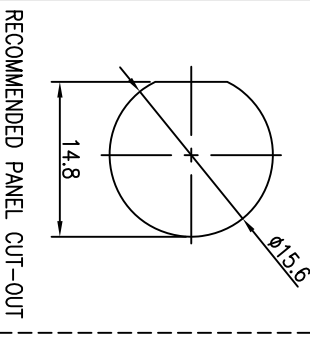
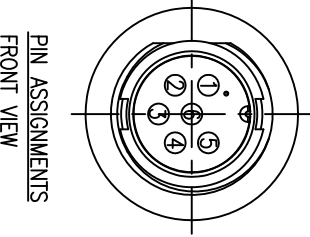

E	SHRINK TUBE	1	Ø2*30	BLACK
D	SHRINK TUBE	1	Ø8*15	BLACK
C	SHRINK TUBE	3	Ø2*7	BLACK
B	CABLE	1	UL2464 24#*1P+AL+D +B(UV RESISTANT)	BLACK (PVC JACKET)
A	CONNECTOR	1	P/N:2CT3002-W06300	BLACK
NO	DESCRIPTION	QTY	MATERIAL	PLATING & COLOR

UNLESS OTHERWISE SPECIFIED TOLERANCES

DECIMALS:	ANGLES:
X :±0.5	X :±2°
X.X :±0.3	X.X :±1°
X.XX :±0.2	

Singatron Enterprise Co., Ltd.
信管企業股份有限公司
CIRCULAR STANDARD SIZE (SOLDER/LOCK TYPE)
MALE CONN. MALE 6PIN (5A)
PART NO.2CT3002-W06302

CHKD	Stave	SCALE 2:1	UNIT: mm	REV: B
APVD	Max	SIZE: A3	SHEET: 1 OF 1	

CUSTOMER COPY