

REV.	ECN NO.	OR DESCRIPTION	REVISED	DATE
A	PDR NO:1091123-3A	HARLEN	2010.03.08	
B	ECN NO:S110707	HARLEN	2011.8.2	
C	ECN NO:S121109	YF	2014.03.28	

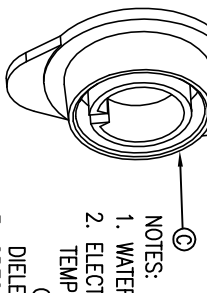

- NOTES:
1. WATERPROOF RATE: IP55
 2. ELECTRICAL CHARACTERISTICS
 - TEMPERATURE RANGE: -20°C TO +80°C
 - CURRENT RATING: 10A
 - DIELECTRIC WITHSTANDING VOLTAGE: 1000V AC FOR ONE MINUTE
 - SPECIFICATIONS: SEE "CIRCULAR SERIES SPECIFICATIONS"
 - TO CONFORM TO SINGATRON HAZARDOUS SUBSTANCE FREE SPEC.
 - GREEN PRODUCT IDENTIFICATION LABEL ON PACKAGING: [Cap. Pass]
 - 螺絲, 防護蓋以附件形式包裝出貨
 - THE TORQUE OF SCREWING: 3.5KGF MAX
 - AFTER 5000CYCLES LIFE TEST OF DUST CAP WITHOUT ANY FRACTURES OR CRACKS OF THE BAD SITUATION.

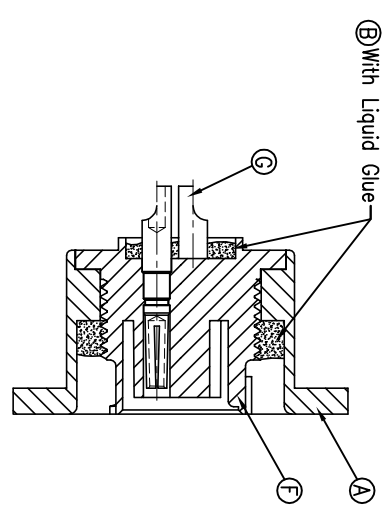
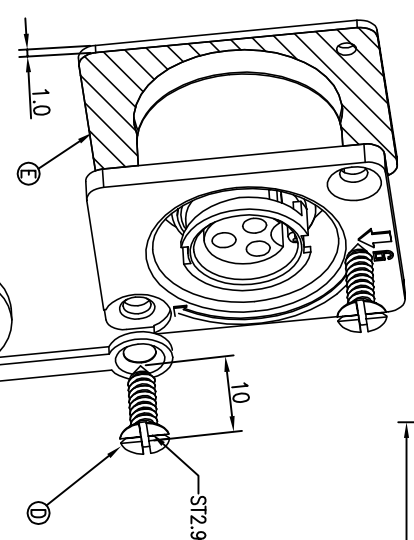
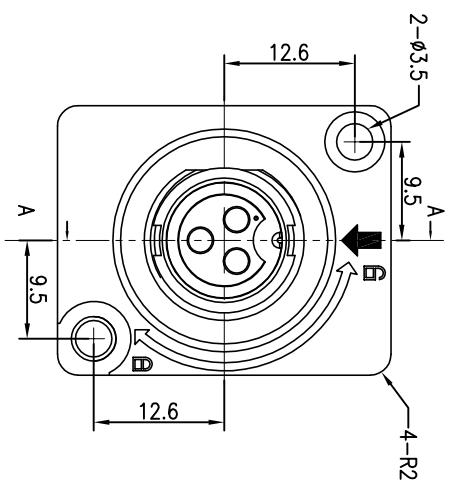
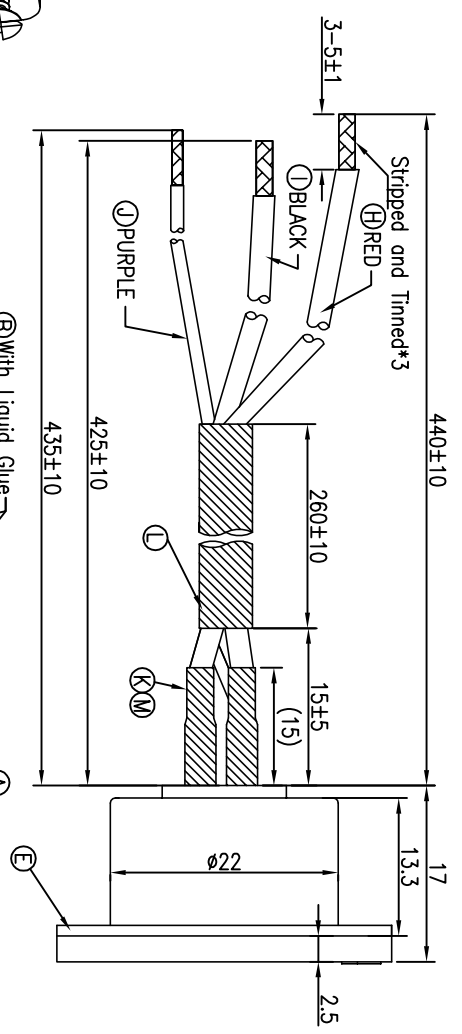
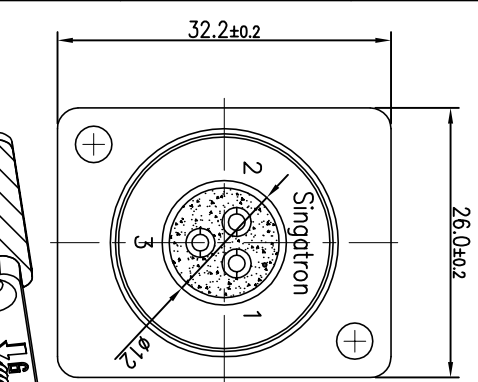
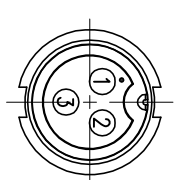

PIN ASSIGNMENTS
FRONT VIEW

WIRE COLOR	CONN.	PIN OUT
PURPLE	3	
BLACK	2	
RED	1	

PIN OUT

MATERIAL	PLATING & COLOR
M TERMINAL	TIN PLATING
L SHRINK TUBE	BLACK
K SHRINK TUBE	BLACK
J WIRE	PURPLE
I WIRE	BLACK
H WIRE	RED
G FEMALE PIN	1u" GOLD PLATING OVER NICKEL PLATING
F PANEL BODY	BLACK
E GASKET	BLACK
D SCREW	N/A
C DUST CAP	BLACK
B LIQUID GLUE	BLACK
A HOUSING	BLACK

UNLESS OTHERWISE SPECIFIED TOLERANCES

DECIMALS: ANGLES:

±0.5 X ±2'
±0.3 X.X ±1'
±0.2 X.XX

Singatron Enterprise Co., Ltd.
信譽企業股份有限公司

TITLE POWER 3PIN(10A)

DWN YF PART NO. 2CT9020-W03444
CHKD Harlen SCALE 2:1 UNIT: mm
APVD Quon SIZE: A3 SHEET: 1 OF 1 REV: C

CUSTOMER COPY