

REV	ECN NO OR DESCRIPTION	REVISED	DATE
A	PDR NO : T100715-1A	HARLEN	2010.07.22
B	ECN NO:S110707	HARLEN	2011.8.2
C	ECN NO:S121109	YF	2014.03.28

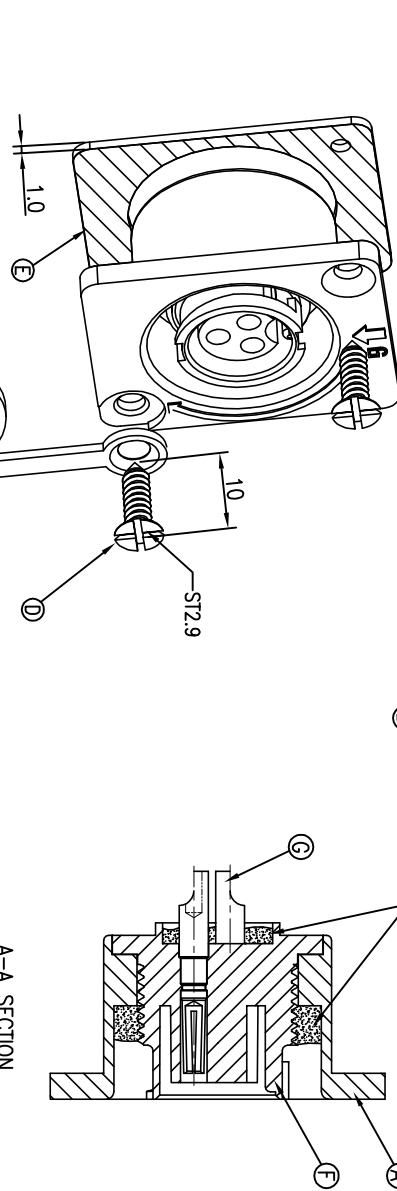

- NOTES:
1. WATERPROOF RATE: IP55
 2. ELECTRICAL CHARACTERISTICS TEMPERATURE RANGE: -20°C TO +80°C
 3. CURRENT RATING: 10A
 4. DIELECTRIC WITHSTANDING VOLTAGE: 1000V AC FOR ONE MINUTE
 5. SPECIFICATIONS: SEE "CIRCULAR SERIES SPECIFICATIONS".
 6. TO CONFORM TO SINGATRON HAZARDOUS SUBSTANCE FREE SPEC.
 7. GREEN PRODUCT IDENTIFICATION LABEL ON PACKAGING: G.P. PASS
 8. 螺絲 防護蓋以附件形式包裝出貨
 9. 7. THE TORQUE OF SCREWING 3.5KGf MAX
 10. 8. AFTER 5000CYCLES LIFE TEST OF DUST CAP WITHOUT ANY FRACTURES OR CRACKS OF THE BAD SITUATION.

L	SHRINK TUBE	1	Ø3.2*10mm (含膠)	BLACK
K	SHRINK TUBE	1	Ø5.0*260mm	BLACK
J	SHRINK TUBE	2	Ø3.0*15mm	BLACK
I	WIRE	1	UL1015 20AWG	BLACK
H	WIRE	1	UL1015 20AWG	RED
G	FEMALE PIN	3	Phosphor Bronze	1u" GOLD PLATING OVER NICKEL PLATING
F	PANEL BODY	1	PA66+30%GF	BLACK
E	GASKET	1	EPDM ADHESIVE	BLACK
D	SCREW	2	STAINLESS STEEL	N/A
C	DUST CAP	1	N/A	BLACK
B	LIQUID GLUE	1	HYTREL	BLACK
A	HOUSING	1	PA66+30%GF	BLACK
NO	DESCRIPTION	QTY	MATERIAL	PLATING & COLOR
UNLESS OTHERWISE SPECIFIED TOLERANCES				
Singatron Enterprise Co., Ltd. 信晉企業股份有限公司				
TITLE		POWER SPIN(10A)		
DWN	YF	PART NO.2CT13020-W0344B		
CHKD	Harlen	SCALE 2:1	UNIT: mm	
APVD	Quan	SIZE: A3	SHEET: 1 OF 1	REV: C
CUSTOMER COPY				

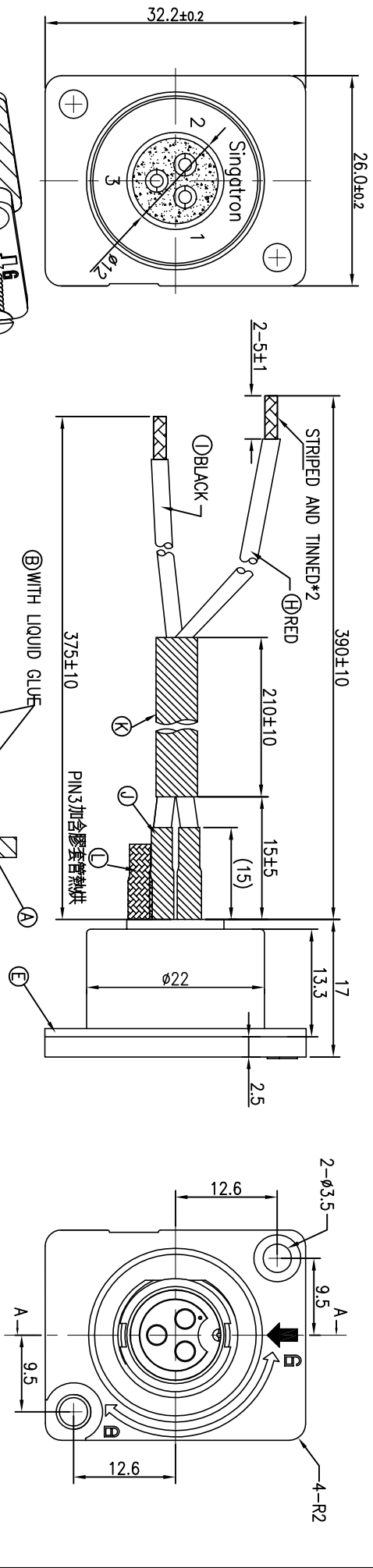
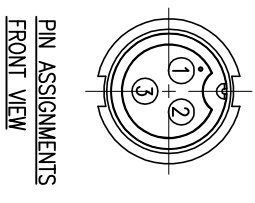

PIN ASSIGNMENTS FRONT VIEW		PIN OUT	
N/A	3	WIRE COLOR	CONN.
BLACK	2	RED	1
RED	1		