

REV.	ECN NO OR DESCRIPTION	REVISED	DATE
A	PDR NO:T120424-1A	Harlen	2012.5.31

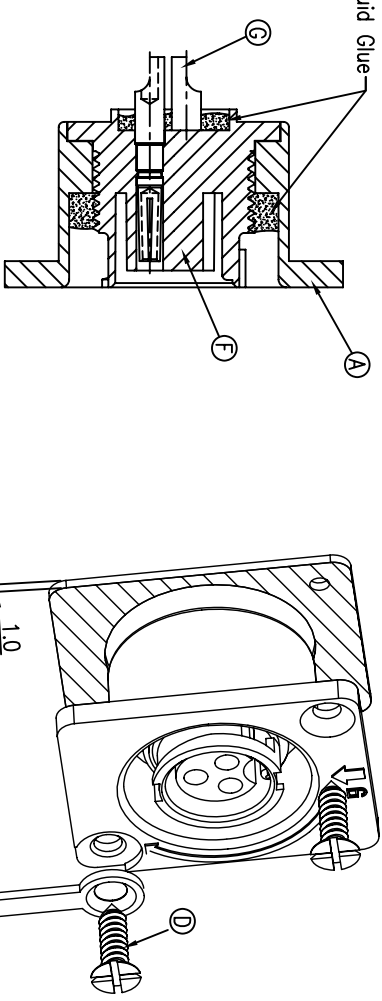

3	YELLOW
2	BLACK
1	WHITE
CONN.	WIRE COLOR
	PIN OUT

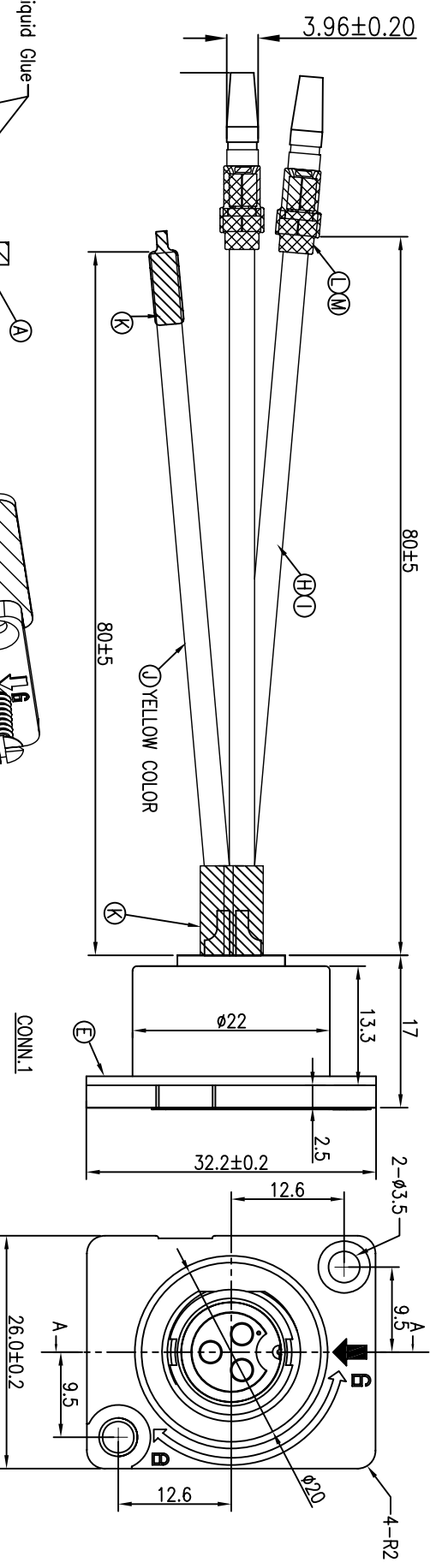
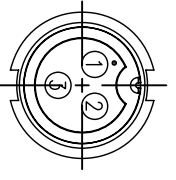

A-A SECTION

- NOTES:
1. WATERPROOF RATE: IP55
 2. ELECTRICAL CHARACTERISTICS
TEMPERATURE RANGE: -20°C TO +80°C
CURRENT RATING: 10A
DIELECTRIC WITHSTANDING VOLTAGE: 1000V AC FOR ONE MINUTE
 3. SPECIFICATIONS: SEE "CIRCULAR SERIES SPECIFICATIONS".
 4. TO CONFORM TO SINGATRON HAZARDOUS SUBSTANCE FREE SPEC.
 5. GREEN PRODUCT IDENTIFICATION LABEL ON PACKAGING: **GREEN PASS**
 6. 螺絲及防塵蓋以附件形式包裝出貨
 7. THE TORQUE OF SCREWING 3.5KGf MAX
 8. AFTER 5000CYCLES LIFE TEST OF DUST CAP WITHOUT ANY FRACTURES OR CRACKS OF THE BAD SITUATION.

M	TUBE	2	BULLET SERIES SLEEVE	WHITE
L	FEMALE TERMINAL	2	BULLET TERMINAL	TIN PLATING
K	HEAT SHRINK TUBE	4	ø3.0*15mm	BLACK
J	WIRE	1	UL1015 18AWG	YELLOW
I	WIRE	1	UL1015 18AWG	BLACK
H	WIRE	1	UL1015 18AWG	WHITE
G	FEMALE PIN	3	Phosphor Bronze	1u" GOLD PLATING OVER NICKEL PLATING
F	PANEL BODY	1	PA66+30%GF	BLACK
E	GASKET	1	EPDM 70'	BLACK
D	SCREW	2	STAINLESS STEEL	N/A
C	DUST CAP	1	HYTREL 4056	BLACK
B	LIQUID GLUE	1		BLACK
A	HOUSING	1	PA66+30%GF	BLACK
NO	DESCRIPTION	QTY	MATERIAL	PLATING & COLOR

UNLESS OTHERWISE SPECIFIED TOLERANCES

DECIMALS: ANGLES:

X : ±0.5 X : ±.2'
X.X : ±0.3 X.X : ±.1'
X.XX : ±0.2

Singatron Enterprise Co., Ltd.
信音企業股份有限公司

PART NO. 2CT13020-W034C5H

SCALE 2:1 UNIT: mm

SIZE: A3 SHEET: 1 OF 1 REV: A

CUSTOMER COPY