

REV.	ECN NO OR DESCRIPTION	REVISED	DATE
A	PDR NO.:1140319-4A	YF	2015.04.10

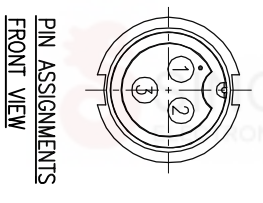
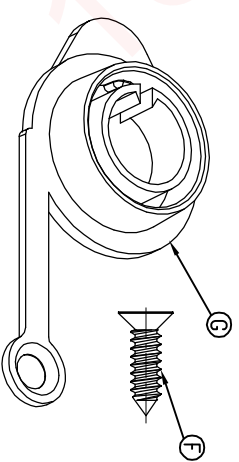
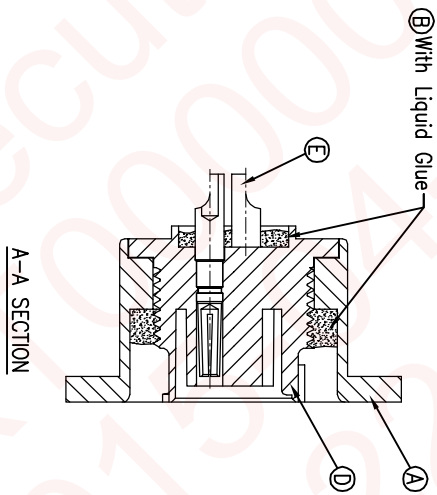
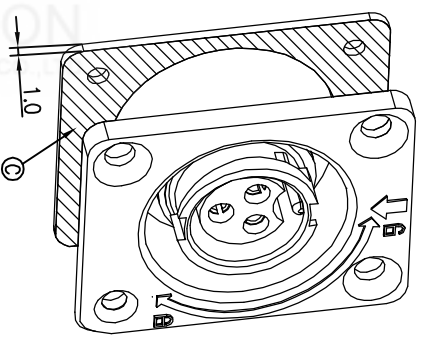
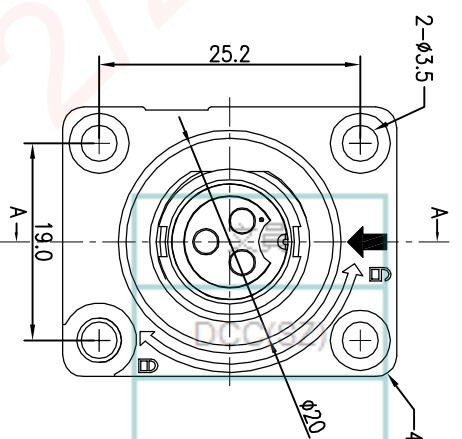
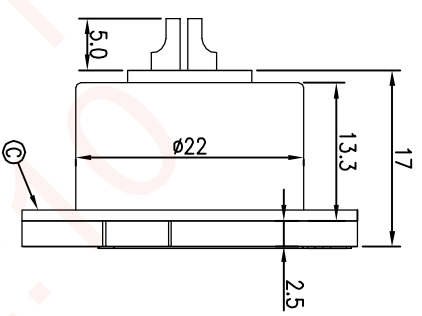
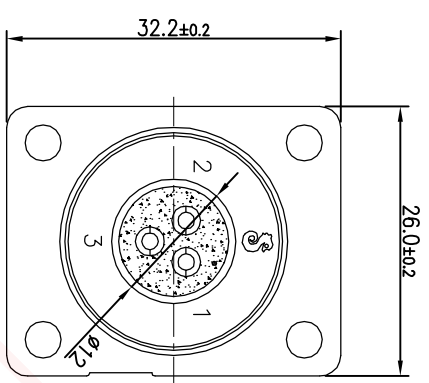

- NOTES:
1. WATERPROOF RATE: IP55
  2. ELECTRICAL CHARACTERISTICS TEMPERATURE RANGE: -40°C TO +100°C
  3. CURRENT RATING: 10A
  4. SPECIFICATIONS: SEE "CIRCULAR SERIES SPECIFICATIONS".
  5. TO CONFORM TO SINGATRON HAZARDOUS SUBSTANCE FREE SPEC.
  6. GREEN PRODUCT IDENTIFICATION LABEL ON PACKAGING: **GREEN**
  7. THE TORQUE OF SCREWING: 3.5KGF MAX
  8. AFTER 5000CYCLES LIFE TEST OF DUST CAP WITHOUT ANY FRACTURES OR CRACKS OF THE BAD SITUATION.
  9. 螺絲/PCS, 防塵蓋以附件形式包裝在吸塵器中出貨

G	DUST CAP	1	HYREL 4056	BLACK
F	SCREW	4	STAINLESS STEEL	BLACK
E	FEMALE PIN	3	Phosphor Bronze	1u" GOLD PLATING OVER NICKEL PLATING
D	PANEL BODY	1	PA66+30%GF	BLACK
C	GASKET	1	SILICONE ADHESIVE	BLACK
B	LIQUID GLUE	1	N/A	BLACK
A	HOUSING	1	PA66+30%GF	BLACK
NO	DESCRIPTION	QTY	MATERIAL	PLATING & COLOR
UNLESS OTHERWISE SPECIFIED TOLERANCES				
Singatron Enterprise Co., Ltd. 信晉企業股份有限公司				
TITLE: 3PIN POWER SOCKET(10A)				
DWN	YF	PART NO. 2CT3020-W034D0H		
CHKD	Horlen	SCALE 2:1 UNIT: mm		
APVD	Steve	SIZE: A3 SHEET: 1 OF 1 REV: A		
CUSTOMER COPY				

2015/04/16  
 8:50:50