

REV.	ECN NO.	OR DESCRIPTION	REVISED	DATE
A	PDR NO.:	A180914-5B~5E	JF	2019.06.19

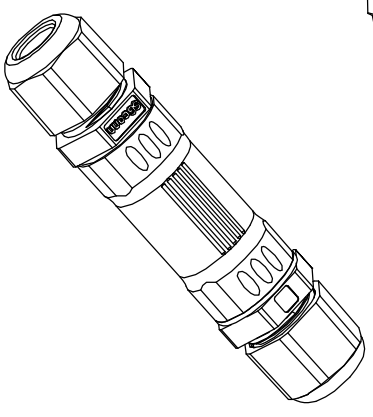
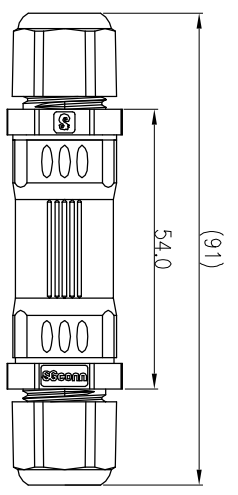
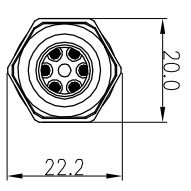
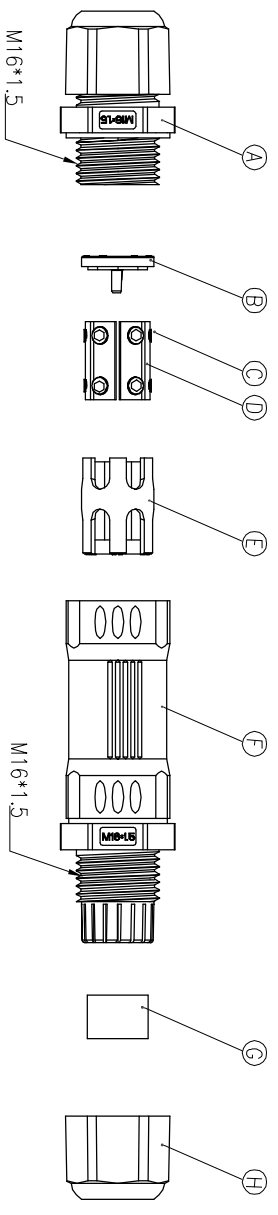

- NOTES:
1. WATERPROOF RATE: IP67  
IP67: IMMersed IN 1M WATER FOR 30 MINUTES
  2. CABLE RANGE: SEE TABLE\_1
  3. TO CONFORM TO THE SINGATRON HAZARDOUS SUBSTANCE FREE SPEC.
  4. GREEN PRODUCT IDENTIFICATION LABEL ON PACKAGING: **GR-TR45**

TABLE\_1

PART NO.	WIRE RANGE	TERMINAL QTY	SCREW QTY	CABLE RANGE
2CT3100-D00451H	22~18AWG	2	4	φ4.0mm~φ6.0mm
2CT3100-D00452H	22~18AWG	3	6	φ4.0mm~φ6.0mm
2CT3100-D00453H	22~18AWG	4	8	φ6.0mm~φ9.0mm
2CT3100-D00454H	22~18AWG	6	12	φ6.0mm~φ9.0mm

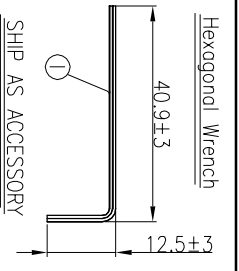

ITEM NO.	DESCRIPTION	QTY	MATERIAL	PLATING & COLOR
I	Hexagonal Wrench	1	N/A	BLACK
H	SEALING NUT	1	PA66	BLACK
G	SEAL	1	EPDM	BLACK
F	CLAMP RING	1	PA66	BLACK
E	BARREIR	1	PA66	BLACK
D	TERMINAL	*	COPPER ALLOY	N/A
C	SCREW	*	COPPER ALLOY	N/A
B	COVER	1	PA66	BLACK
A	CABLE GLAND	1	M16*1.5	BLACK
NO	DESCRIPTION	QTY	MATERIAL	PLATING & COLOR

UNLESS OTHERWISE SPECIFIED TOLERANCES

DECIMALS:	ANGLES:
X : ±0.5	X : ±2°
X.X : ±0.3	X.X : ±1'
X.XX : ±0.2	

Singatron Enterprise Co., Ltd.  
信亨企業股份有限公司

CABLE JOINER

TITLE

DWN JF PART NO. 2CT3100-D0045XH

CHKD Cerry SCALE 1:1 UNIT: mm

APVD William SIZE: A3 SHEET: 1 OF 1 REV: A

CUSTOMER COPY