

REV.	E	C	N	NO	OR	DESCRIPTION	REVISED	DATE
A	PDR	NO.:	S131205-4B~4E	Harlen	2014.12.31			

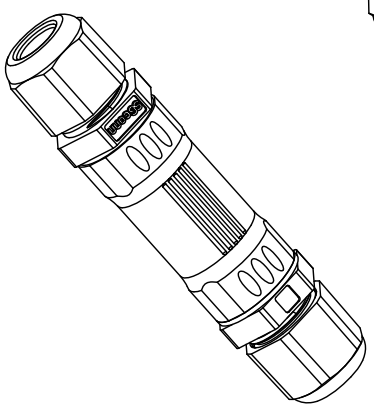
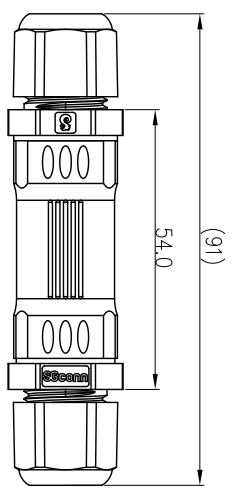
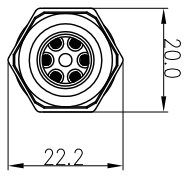
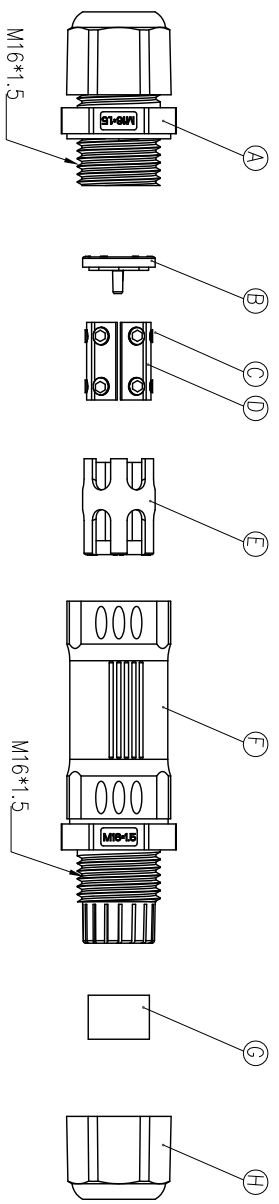

- NOTES:
1. WATERPROOF RATE: IP67
IP67: IMMersed IN 1M WATER FOR 30 MINUTES
 2. CABLE RANGE: SEE TABLE_1
 3. TO CONFORM TO THE SINGATRON HAZARDOUS SUBSTANCE FREE SPEC.
 4. GREEN PRODUCT IDENTIFICATION LABEL ON PACKAGING: **GR PASS**

TABLE_1

PART NO.	WIRE RANGE	TERMINAL QTY	SCREW QTY	CABLE RANGE
2CT3100-W00215H	22~18AWG	2	4	φ4.0mm~φ6.0mm
2CT3100-W00216H	22~18AWG	3	6	φ4.0mm~φ6.0mm
2CT3100-W00217H	22~18AWG	4	8	φ6.0mm~φ9.0mm
2CT3100-W00218H	22~18AWG	6	12	φ6.0mm~φ9.0mm

NO	DESCRIPTION	QTY	MATERIAL	PLATING & COLOR
H	SEALING NUT	1	PA66	BLACK
G	SEAL	1	EPDM	BLACK
F	CLAMP RING	1	PA66	BLACK
E	BARRIER	1	PA66	BLACK
D	TERMINAL	*	COPPER ALLOY	N/A
C	SCREW	*	COPPER ALLOY	N/A
B	COVER	1	PA66	BLACK
A	CABLE GLAND	1	M16*1.5	BLACK
NO	DESCRIPTION	QTY	MATERIAL	PLATING & COLOR

UNLESS OTHERWISE SPECIFIED TOLERANCES

DECIMALS: ANGLES:

X : ±0.5 X : ±2°

X.X : ±0.3 X.X : ±1'

X.XX : ±0.2

TITLE	CABLE JOINER
DWM	Harlen
CHKD	JF
APVD	STEVE
PART NO. 2CT3100-W0021XH	
SCALE 1:1 UNIT: mm	
SIZE: A3 SHEET: 1 OF 1	
REV: A	

Singatron Enterprise Co., Ltd.
信亨企業股份有限公司

CUSTOMER COPY