

REV/ECN	NO OR DESCRIPTION	REVISED	DATE
A	PDR NO.:141027-1A	Vicky	2015.11.03

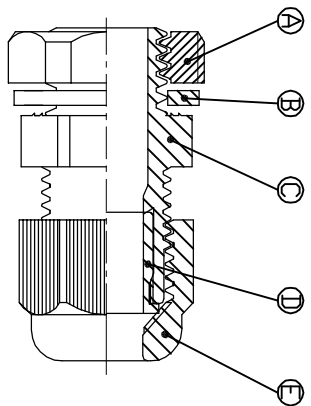
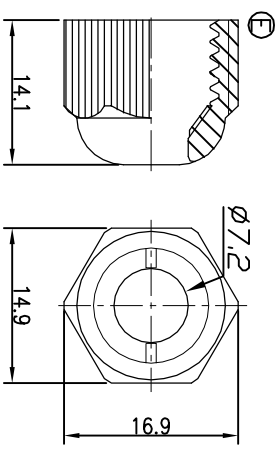
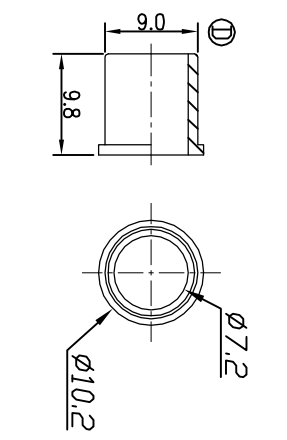
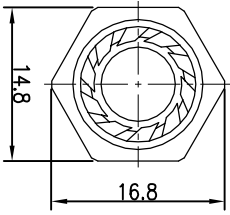
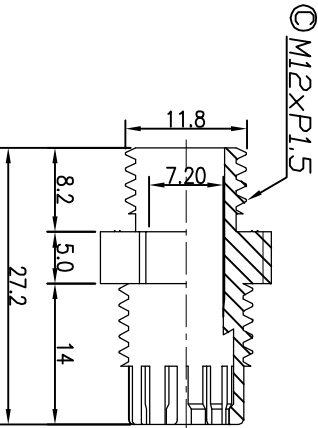
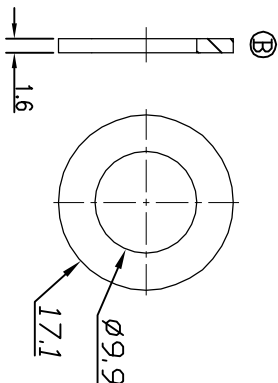
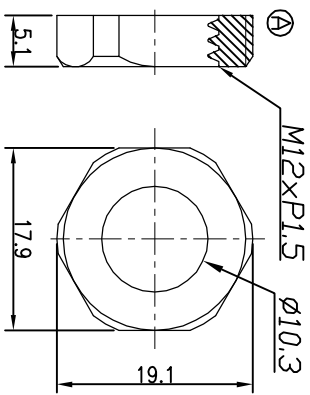

- NOTES:
1. WATERPROOF RATE: IP67(WHEN PROPERLY MATED)
 2. GENERAL FLASH:0.05mm max
 3. Recommended Panel Mounting Hole : 12.5 - 12.7 mm
 4. Cable Range:φ4.7mm~φ6.9mm
 5. TO CONFORM TO THE SINGATRON HAZARDOUS SUBSTANCE FREE SPEC.
 6. GREEN PRODUCT IDENTIFICATION LABEL ON PACKAGING:

NO	DESCRIPTION	QTY	MATERIAL	PLATING & COLOR
E	SEALING NUT	1	PA66 UL94V-2	GRAY
D	SEAL	1	EPDM	BLACK
C	CLAMP RING	1	PA66 UL94V-2	GRAY
B	GASKET	1	EPDM	BLACK
A	NUT	1	PA66 UL94V-2	GRAY

UNLESS OTHERWISE SPECIFIED TOLERANCES

DECIMALS:	ANGLES:
X : ±0.5	X : ±2°
X.X : ±0.3	X.X : ±1'
X.XX : ±0.2	

TITLE M12*1.5 CABLE GLAND, MGB12-07B-ST(GRAY)
 DWG Vicky PART NO. 2CT3100-W00351H
 CHKD Harlen SCALE 2:1 UNIT: mm
 APVD Steve SIZE: A3 SHEET: 1 OF 1 REV: A

Singatron Enterprise Co., Ltd.
 信晉企業股份有限公司

CUSTOMER COPY