

REV	ECN NO.	OR DESCRIPTION	REVISED	DATE
A	PDR NO.:A200309-2C	LEI	2020.06.22	
B	ECN NO.:S202008-C05	LEI	2020.11.27	

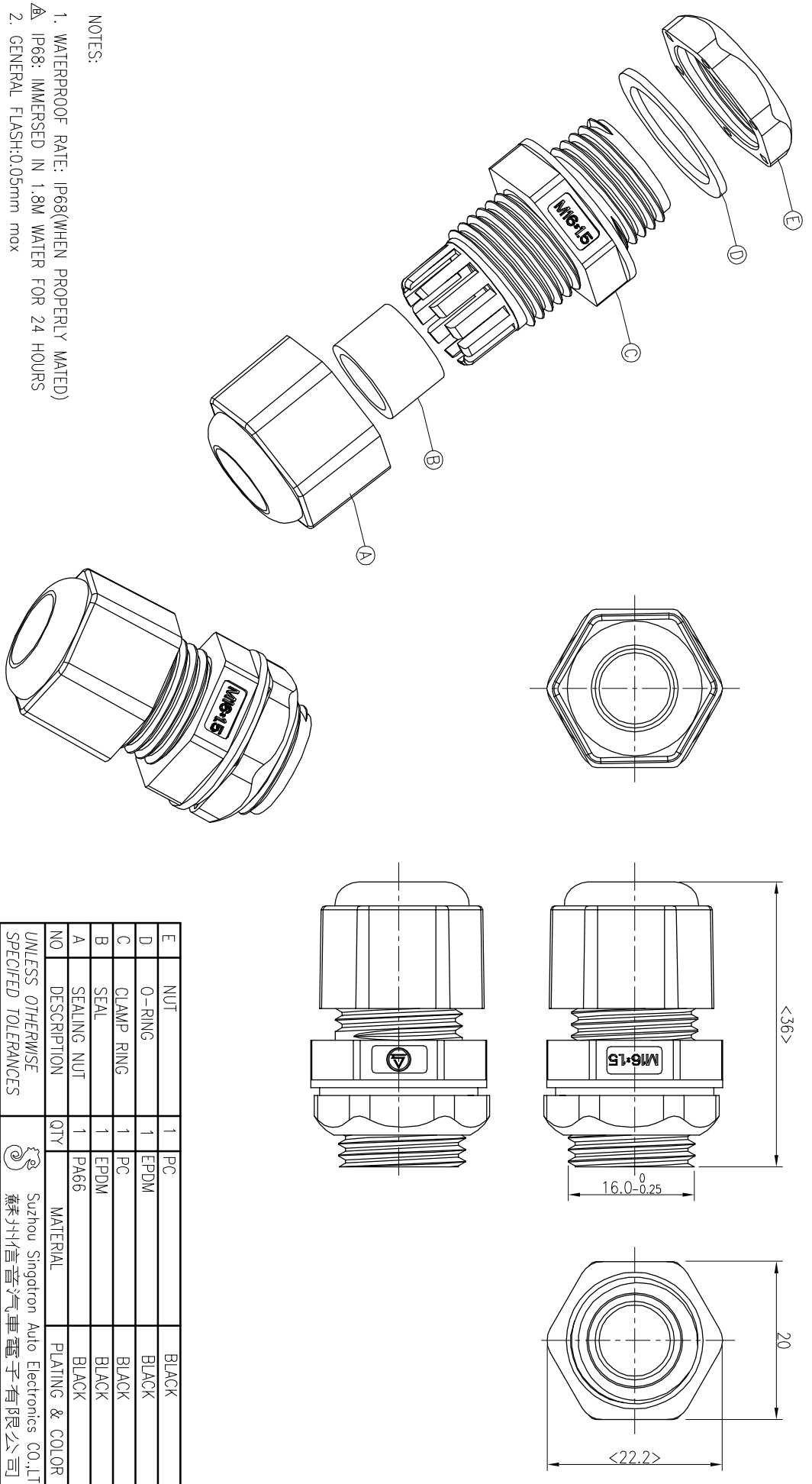

- NOTES:
1. WATERPROOF RATE: IP68(WHEN PROPERLY MATED)
 2. GENERAL FLASH:0.05mm max
 3. Cable Range:ø6.0mm~ø9.0mm
 4. TO CONFORM TO THE SINGATRON HAZARDOUS SUBSTANCE FREE SPEC.
 5. GREEN PRODUCT IDENTIFICATION LABEL ON PACKAGING: GP PASS

NO	DESCRIPTION	QTY	MATERIAL	PLATING & COLOR
E	NUT	1	PC	BLACK
D	O-RING	1	EPDM	BLACK
C	CLAMP RING	1	PC	BLACK
B	SEAL	1	EPDM	BLACK
A	SEALING NUT	1	PA66	BLACK

UNLESS OTHERWISE SPECIFIED TOLERANCES

DECIMALS:	ANGLES:
X :±0.5	X :±2°
X.X :±0.3	X.X :±1°
X.XX :±0.2	

TITLE	PART NO. 2CT3100-W00495H	
DWN	LEI	UNIT: mm
CHKD	Cerry	SCALE 2:1
APVD	William	SIZE: A3
SHEET: 1 OF 1		
REV: B		

CUSTOMER COPY