

REV.	ECN NO OR DESCRIPTION	REVISED	DATE
A	PRODUCT RELEASE	Cheney	2016.12.05

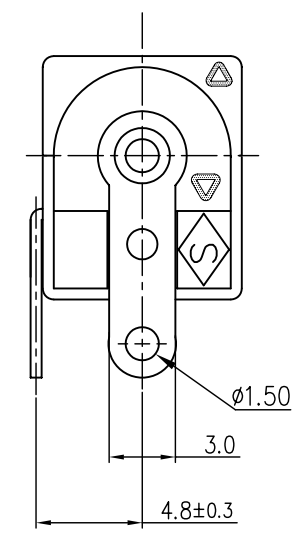

- NOTE:
- 1.RATING: 16 VDC , 3A.
 - 2.CONTACT RESISTANCE: 30mΩ MAX.
 - 3.INSULATION RESISTANCE: 100MΩ MIN. AT 500 VDC.
 - 4.DIELECTRIC STRENGTH: 500 VAC FOR ONE MINUTE.
 5. INSERTION FORCE: 0.5~2.5KGF.
WITHDRAWAL FORCE: 0.5~3.0KGF.
 - 6.LIFE: 5,000 CYCLES.
 - 7.OTHER GENERAL SPEC. TO REFER "2DC-0005-D28H" SPEC.
 8. HALOGEN FREE PRODUCT IDENTIFICATION MARK ON PRODUCT:
 - 9.HALOGEN FREE PRODUCT IDENTIFICATION LABEL ON PACKAGING:
 - 10.PACKING: TAPE & REEL

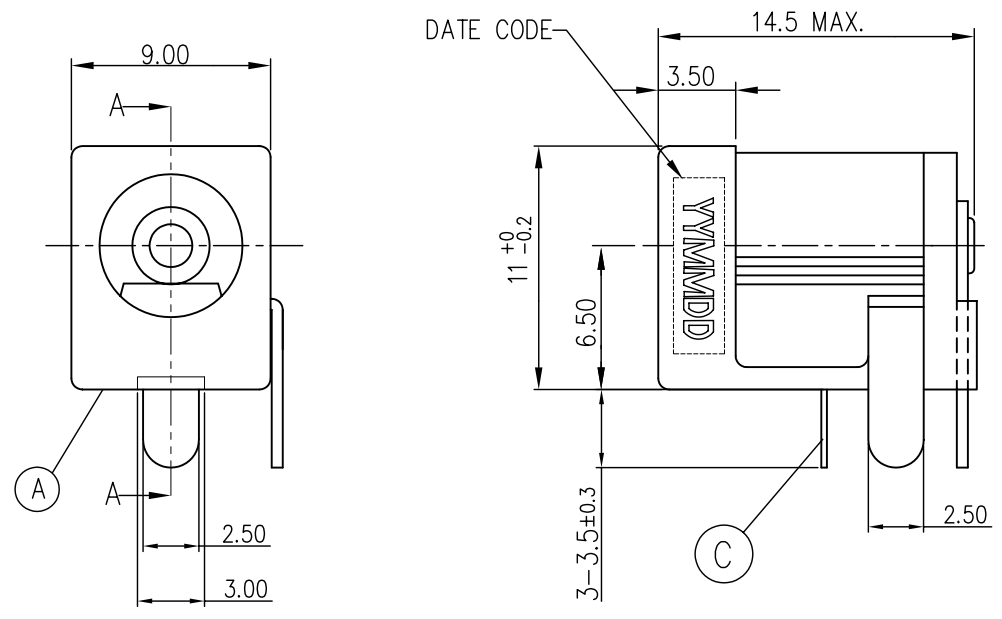
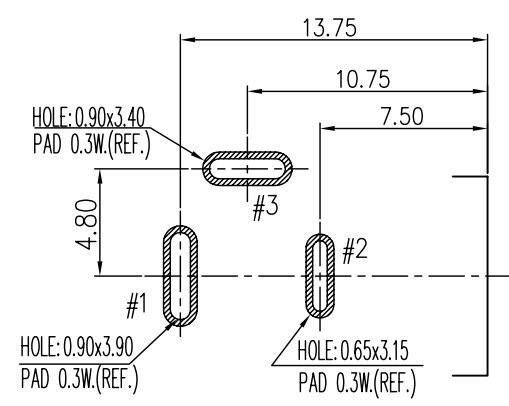
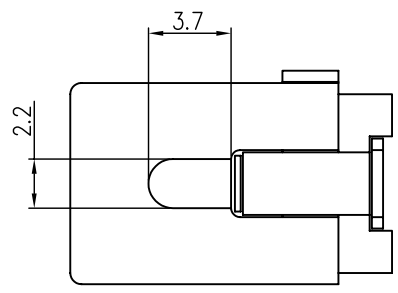
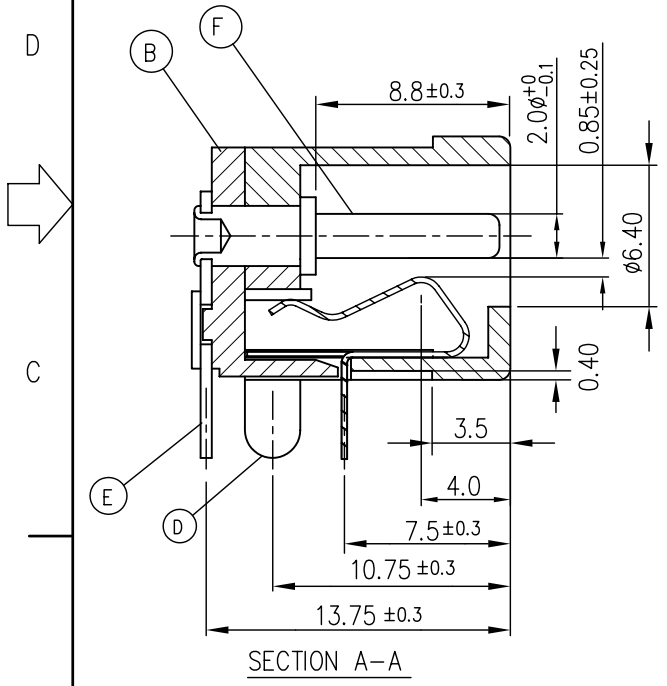

RECOMMENDED PCB LAYOUT
(TOP VIEW)(TOL.:±0.05)

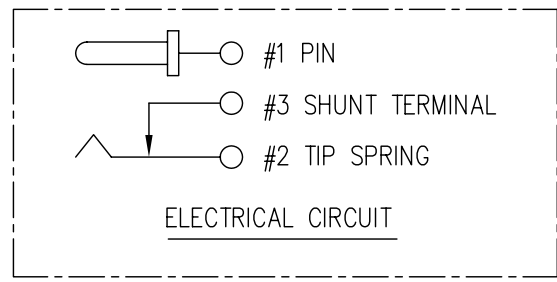
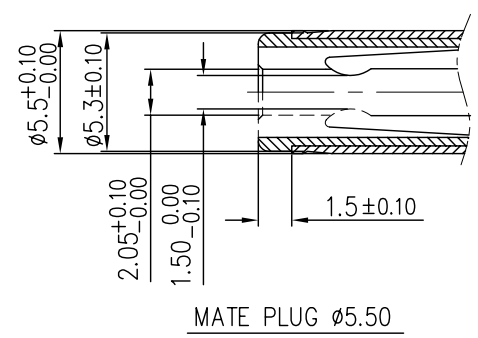

F	PIN	1	BRASS	Ni60u"MIN.
E	TERMINAL	1	COPPER ALLOY,0.5T	Ag20u"MIN.
D	SHUNT TERMINAL	1	COPPER ALLOY,0.5T	Ag20u"MIN.
C	TIP SPRING	1	COPPER ALLOY,0.25T	Ag20u"MIN.
B	COVER	1	HI-THERMAL PLASTIC W/ 30%GF.,UL94V-0	BLACK COLOR
A	BODY	1	HI-THERMAL PLASTIC W/ 30%GF.,UL94V-0	BLACK COLOR
NO	DESCRIPTION	QTY	MATERIAL	PLATING & COLOR
UNLESS OTHERWISE SPECIFIED TOLERANCES		Singatron Enterprise Co., Ltd. 信音企業股份有限公司		
DECIMALS:		TITLE DC POWER JACK		
X	:±0.5	DWN		
X.X	:±0.3	CHKD		
X.XX	:±0.2	APVD		
		PART NO.2DC-0005-D28H		
		SCALE 1:1		UNIT:mm
		SIZE:A3		SHEET1OF1
		REV:A		
CUSTOMER COPY				